



Blockchain Quick Facts For Business

A series of one-page fact sheets—everything from Blockchain 101 to the definition of interoperability. These are simple overviews developed by R3 to provide market participants with a basic understanding of what blockchain is, how it works, the Corda platform and its key differentiators.



Contents

What is a blockchain?	1
What is an enterprise blockchain?.....	2
Who is R3?	3
What is Corda?	4
How involved are regulators?.....	5
Data privacy	6
What is consensus?	7
What does decentralization mean?	8
What is interoperability?	9
Who is using Corda? What are some of the applications?.....	10
How does Corda compare to Ethereum / Fabric?	11
What is Corda Settler?	12



What is a blockchain?

Blockchains are data structures where entries, usually transactions, are written to a database in bundles called blocks.

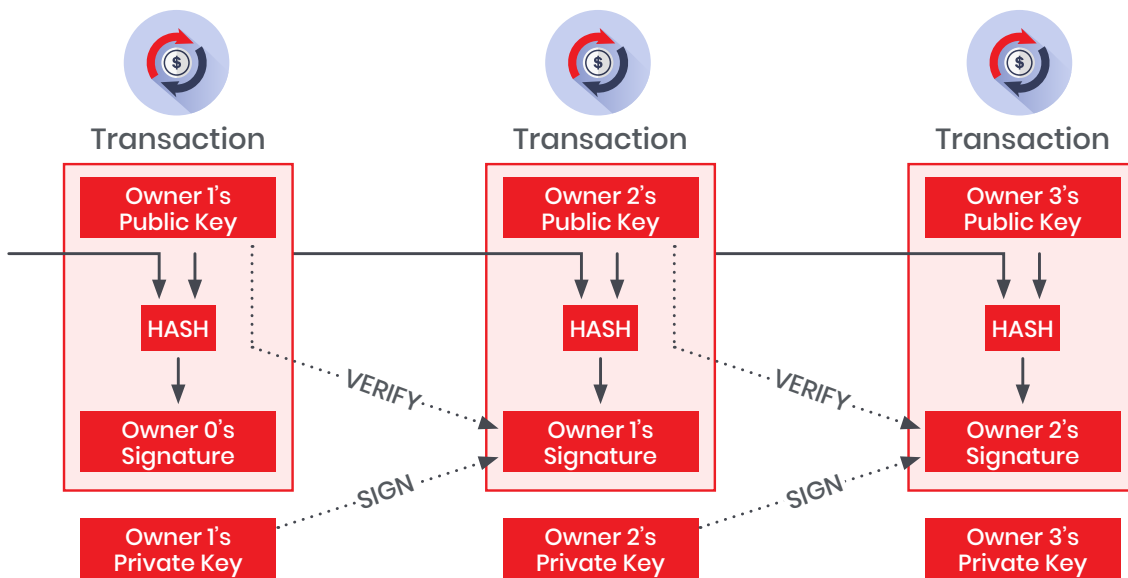

Each **block** refers to a previous block by a unique identifier known as its hash, which is determined by its contents. This forms a chain of blocks. Although blockchains can store any data, they are generally used to store information about digital asset transactions, hence they are often described as a ledger.

The **ledger** is broadcast in a peer-to-peer fashion between participants on the blockchain network. Preset network and consensus rules determine what is acceptable as a transaction and a block, and participants to a blockchain network each validate transactions and blocks according to these rules. This results in each participant holding identical copies of the ledger.

The most well-known blockchain is the Bitcoin blockchain. Bitcoin functions as censorship-resistant digital cash, and is a new payment rail, though its usefulness for payments is tempered by its price volatility. Bitcoin facilitates a more decentralized approach for network-wide agreement on digital asset ownership and payment, with no single institution responsible for settling transactions or maintaining the ledger. This contrasts with traditional

payment systems, which involve a series of book-entry adjustments by specific known and trusted third parties.

Blockchains come in many varieties and different architectures and are designed to solve very different problems. Many blockchains use a coin or token to incentivize people to write blocks and maintain the network, and have designs intended to facilitate transfer of that token. For example, the Ethereum blockchain launched in 2015 in an attempt to create an unstoppable global computer, and has a native token called ether.

Traditional permission-less blockchain platforms—in which all data is shared with all parties—have issues around privacy, scalability and interoperability that render them largely unsuited for global businesses. Corda launched as an open source platform in 2016 with a different aim — to make regulated business across many industries more efficient by providing relevant parties to a transaction current and consistent data. Corda doesn't bundle unrelated transactions together into blocks, nor does it broadcast all data to all participants, unlike the public blockchains Bitcoin and Ethereum.



What is an enterprise blockchain?

Enterprise blockchains provide an industry-level system of recordkeeping, allowing multiple parties, none of whom fully trust each other, to come into and remain in consensus as to the nature and evolution of a set of shared facts. This approach facilitates cross-firm and cross-entity information sharing without a central operator or costly retroactive bilateral reconciliation.

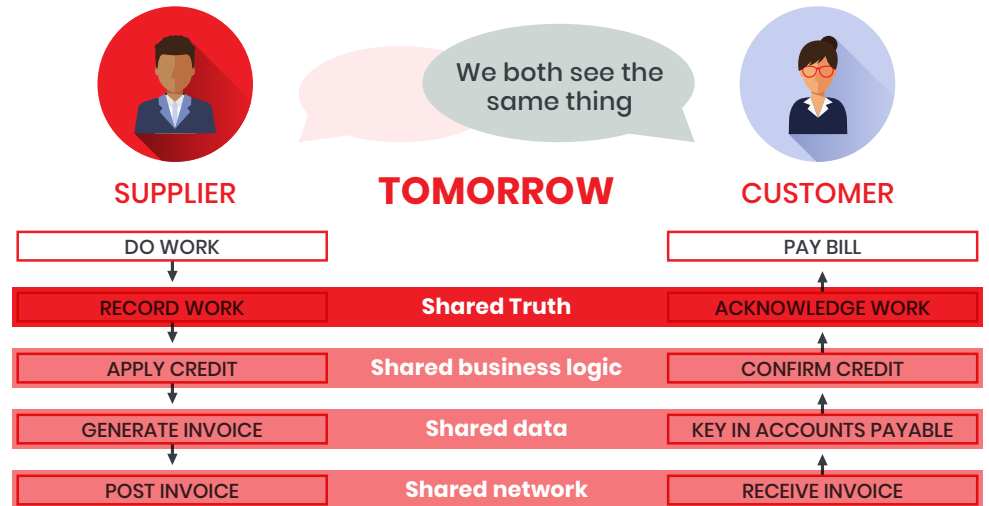

The requirements of businesses that transact are different from the requirements of individuals who want to use censorship resistant digital cash. Because enterprise blockchains solve different problems than public blockchains, they have different designs.

ENTERPRISE BLOCKCHAINS CONTAIN SEVERAL KEY DIFFERENTIATING TRAITS:

- Higher identity standards
- Higher data privacy standards
- Functional requirements of business, such as higher transaction volumes and definitive settlement
- Improved technical support

Regulated enterprises must know who they are transacting with – this requires a robust identity infrastructure in an enterprise blockchain. Counterparties in business also often require legal agreements to accompany many transactions, and require interactions to occur wholly within the parameters of regulatory requirements. Regulated businesses also must meet certain compliance standards, such as KYC and AML.

Both specific regulations and general business logic regarding cross-firm information sharing require full data privacy. For example, HIPPA requires that customer healthcare data is private, companies along a

pharmaceutical supply chain don't want information public, and capital markets counterparties don't want their competitors to know their trading history.

Many wholesale payment and capital market use cases require higher transaction throughput, definitive settlement, and advanced multilateral netting capability. The public Bitcoin network can currently process up to 3.5 transactions per second, while the public Ethereum network can process up to 15. Corda Enterprise can process 200 transactions per second (tps) for 2-party transactions and 1000 tps on a single node.

Settlement is not definitive for many cryptocurrencies and cryptocurrency architectures do not easily facilitate netting. Wholesale payments and capital markets settlements involve significantly larger, definitive, and advanced multilateral settlement capability.

Large organizations also have exacting requirements when it comes to the quality of service or the network infrastructure in which they operate. For example, they require a vendor who supports and facilitates integration with industry-standard enterprise databases such as Microsoft SQL Server and SQL Azure and Oracle.

Public blockchains, and the ecosystems around them, do not offer such services.



Who is R3?

R3 is a leading enterprise software firm that builds and maintains Corda, a next-gen blockchain platform developed for every business in every industry. R3's vision is of a world where everyone can transact directly and privately without friction; a world where business partners operate in perfect synchrony, and duplicated, inconsistent records are a thing of the past.

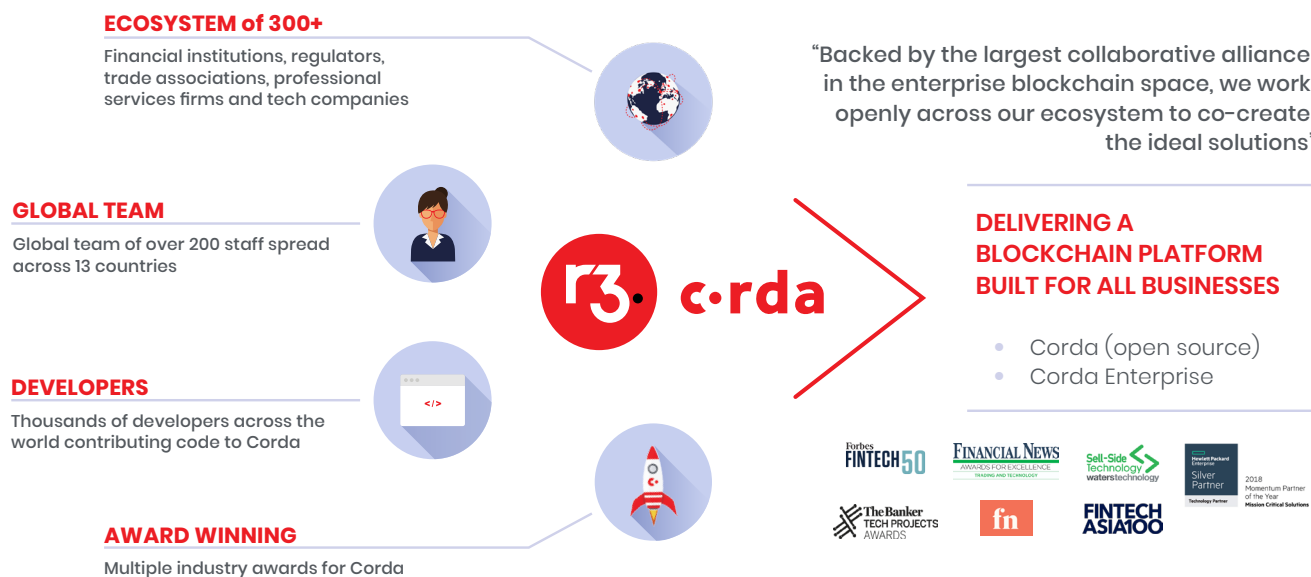

R3 was founded in 2015 in collaboration with some of the world's largest financial institutions. The firm's goal was to match blockchain technology to the needs of specific financial use cases. R3's broader ecosystem quickly realized that no public blockchains on the market served the needs of regulated financial institutions, and that initiatives to retroactively meet these requirements through forks or architectural adaptations would not work within a production environment.

This led R3 in 2016 to build Corda, the only open source blockchain platform built specifically for business. The architecture team leveraged the thorough rigorous requirements gathering process within financial services to build a blockchain platform applicable for transactions across any industry and business use cases. Corda enables businesses to transact directly and in strict privacy, reducing transaction and record-keeping costs and streamlining business operations. In 2018, R3

introduced Corda Enterprise—a commercial version of Corda specifically optimized to meet the demands of modern-day enterprises.

R3 works with an ecosystem of more than 300 ecosystem participants across multiple industries from both the private and public sectors. R3's global team of over 200 professionals in 13 countries is supported by over 2,000 technology, financial, and legal experts drawn from its global member base.

The R3 team is dedicated to both maintaining Corda by constantly upgrading the platform and providing support to firms building applications on Corda, known as CorDapps, that solve the needs of their clients.



What is Corda?

Corda is an open source blockchain platform that is built to record and manage contracts between mutually distrusting parties. Corda was built by R3 in collaboration with the world's largest financial institutions. It was designed to meet the rigorous requirements imposed by financial service regulators, conform to industry standards, and deliver on the promise of blockchain technology making it applicable to any business in the industry.

Corda distinguishes itself from other blockchain platforms through a number of deliberate design decisions. These decisions were made to ensure that the platform could be used to solve real world problems found in any industry.

CORDA HAS THE FOLLOWING CHARACTERISTICS:

- Supports transactions between strictly regulated entities
- Allows counterparties to know each other's identity
- Protects privacy by not globally broadcasting transaction data
- Enables the creation of legally enforceable transactions
- Scales to support a global system of transactions

Corda addresses many of the challenges of building an enterprise-ready blockchain network with its unique *point-to-point* architecture. This separation allows Corda to achieve the openness of public networks while retaining the security and privacy characteristics of a private network.

Corda removes costly friction in business transactions by enabling businesses to transact directly. Using smart contract and blockchain technology, Corda allows existing business networks to reduce transaction and record-keeping costs and to streamline business operations.

Currently, there are two versions that make up the Corda platform: Corda Enterprise and Corda open-source.

Corda Enterprise is the commercial version of Corda. It is optimized to meet the demands of modern day businesses. Corda Enterprise is fully interoperable and compatible

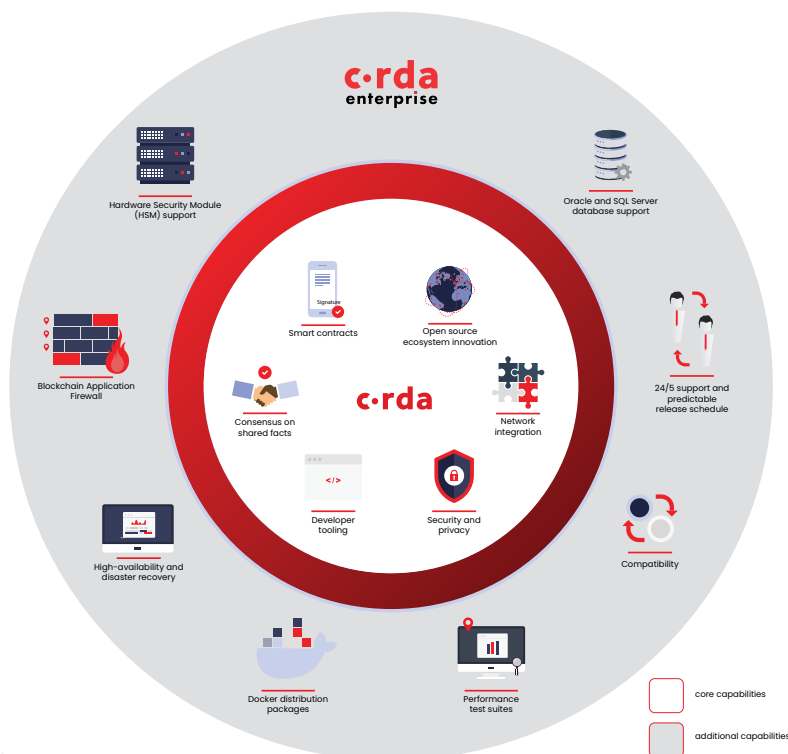

with Corda open source. It adds mission critical features including, but not limited to, resilience, enhanced security and high availability. It also includes the world's only Blockchain Application Firewall which enables Corda Enterprise to be deployed inside corporate data centers while retaining the ability to communicate securely with other nodes anywhere else in the world.

Corda Enterprise is designed to meet the industry standard needs of the institutions that require commercial production capabilities.

Corda open source is an open application framework that is available to global developers and designed for early adoption, integration and proof of concept development. It is suitable for companies with a relatively simple IT structure. However, many institutions, especially large and complex ones, have more stringent requirements regarding production capabilities. While Corda remains open, Corda Enterprise harnesses the most appropriate elements from the core Corda offering and fine-tunes them for the enterprise market.



How involved are regulators?

Since inception, R3 has made regulatory engagement a key priority for the company. We have done so for a very simple reason: we are looking to deploy Corda in the most heavily regulated industries in the world, and without a comprehensive public/private collaborative working model, the development and deployment of blockchain could be stopped in its tracks. Excellent technology and deep financial experience are not enough to make Corda a success. Public sector actors need to understand what we are building, why we are building it, and how it can improve the functioning of the markets, market participants and the regulators themselves. We clearly see the potential benefits of blockchain and we take it upon ourselves to help regulators see them as well.

R3 has expanded its deep engagement around the world by meeting with more than 150 government agencies at all levels. We have invited public sector actors from around the world to join the R3 ecosystem and currently have over 25 regulator members. These broad and deep relationships with regulators have allowed R3 to incorporate key regulatory requirements into the design of Corda. We have hosted two day workshops for regulators, provided deepdives into Corda and our projects, included regulators in projects, participated in over a dozen conferences put on by regulators, responded to 15+ requests for comment from regulators, and trained regulators on Corda.

R3 HAS BUILT OUT A PORTFOLIO OF PROJECTS, MANY OF WHICH DIRECTLY INCLUDE REGULATORS AND CENTRAL BANKS AS PARTICIPANTS:

- **Maison:** Regulatory reporting using blockchain technology. With an initial focus on mortgage regulatory reporting, R3 collaborated with the UK's Financial Conduct Authority (FCA) and member banks to develop a near real-time regulatory reporting prototype.
- **Jasper:** Settling central bank issued assets (CAD) on a blockchain network, working with the Bank of Canada, Payments Canada and other R3 members located in the region.
- **Digital Street:** Her Majesty's Land Registry (UK) – Understanding how the innovative use of blockchain, distributed ledgers and smart contracts, could revolutionize the land registration and property buy-sell process.
- **Lionrock:** Digital currency project undertaken in partnership with the Hong Kong Monetary Authority (HKMA) and the 3 note issuing banks in Hong Kong to develop a Digital Hong Kong Dollar prototype on Corda for interbank payments/securities settlement with provision to wholesale customer.
- **Corda KYC:** 39 firms, along with Banco de la República (Central Bank of Colombia), Federal Reserve of Boston, Superintendencia Financiera de Colombia, and Superintendencia de Banca Seguros y AFP de Peru, partnered to complete over 300 transactions on a Corda KYC platform.

The same design features that make Corda the blockchain built for business also make it built for the public sector. Regulators are more actively exploring possibilities offered by, and opportunities to deploy, blockchain technology. As such, we are now beginning to focus on how to get Corda in front of those in the public sector for consideration as a tool they could use. We are doing that through direct engagement as well as through our partner network. We are already in the process of building custom solutions for the public sector, but anticipate an increase in that activity in the near future.

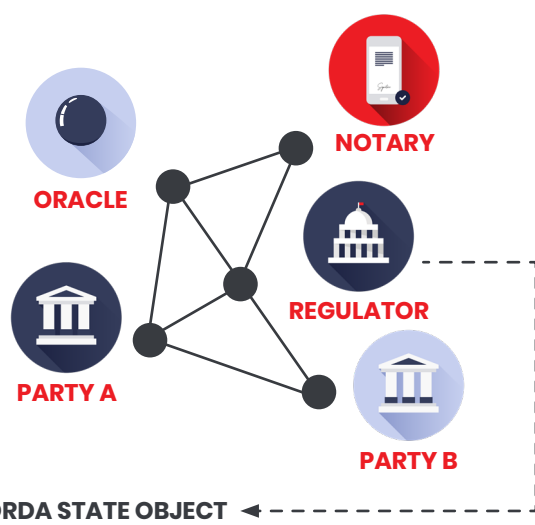

 CORDA STATE OBJECT ←



Data privacy

Unlike public blockchains, Corda is engineered to prioritize the privacy of individual firms' data. Corda already includes many privacy preserving features, and is consistently researching future privacy technologies.

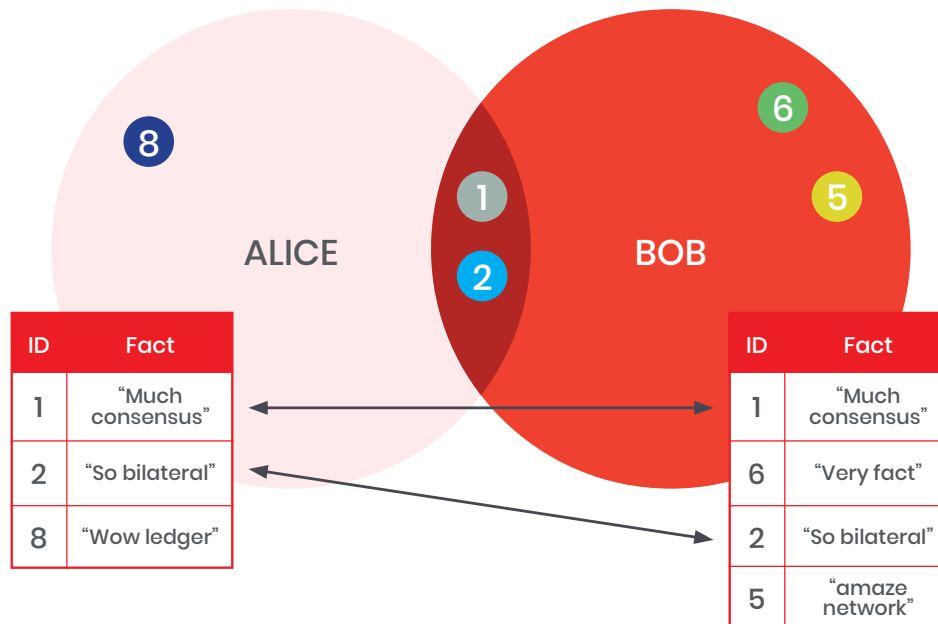

Data within a Corda network travels directly from one party to another. Only parties involved in a transaction are involved in building, validating, and storing it. This contrasts with other blockchain platforms that gossip data widely by default, and then require data privacy layers to obfuscate private data.

In addition, parties have flexibility over what data they share with counterparties. For example, individual sub-components of a transaction can be generated for counterparties who need to grant approval but should not be able to see all the details. These are called transaction "tear offs".

THREE POTENTIAL FUTURE UPGRADES ARE PARTICULARLY NOTABLE:

- Hardware
- Mixed-version networks
- Zero-knowledge proofs

Corda has partnered with Intel to deliver end-to-end encryption of transaction history with chips that use Software Guard Extension (SGX) technology. SGX allows all transaction history to be fully encrypted, unreadable even to the parties of the transaction. This ensures that the history of ownership of assets remain private.

As for all blockchains, some nodes may be able to decipher identity of counterparties over time through IP addresses or examining certificates being sent to notaries. Corda could solve this by using a mix network, a cryptographic solution that repeatedly encrypts data in an onion-like fashion, where the nodes in each layer contains the address of the one above it.

Once the technology is mature enough, Corda intends on migrating to zero-knowledge proofs (ZKP). ZKPs allow one party to prove to another party that a statement is true without revealing any information apart from the fact that the statement is true. The technology is extremely novel, and Corda developers have been deeply researching future implementation.



What is consensus?

Consensus is the process of reaching agreement on a set of shared facts.

Blockchains can achieve consensus in many different ways. For example, Bitcoin uses an algorithm called “Proof of Work” to ensure coins granted to one user can’t also be re-used by the issuer. Alternatively, some blockchains achieve this through a mechanism called “Proof of Stake”. Ultimately, each blockchain platform will use the mechanism that most suits their use-cases.

CORDA SUPPORTS TWO SETS OF CONSENSUS:

- Verification
- Uniqueness

All relevant parties need to sign off on the transaction, which is referred to as verification. Since transaction data is only shared with relevant parties, Corda is more private because each actor in the system can only view a subset of network data.

Corda assures that assets allocated in one transaction cannot be re-used for other purposes, which satisfies uniqueness and solves the double spend problem. On the Corda network, double spend is solved by a group of notaries, referred to as the “notary pool”, who assure transaction uniqueness, provide a definitive ordering of transactions and ensure transaction finality. Corda supports multiple pools so each pool can be optimized to cater to differing business processes.

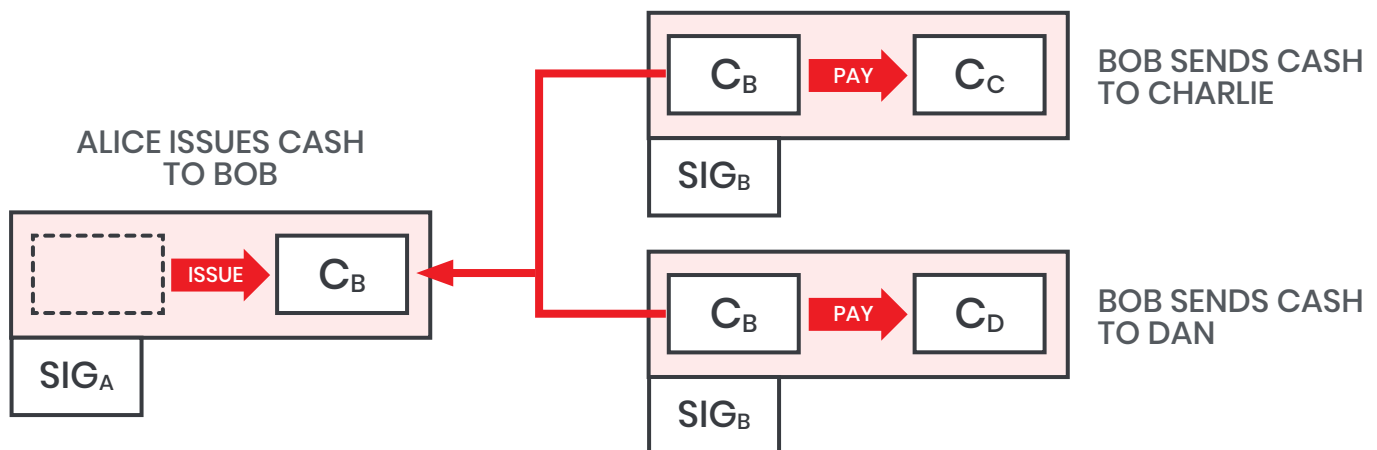

Image shows a violation of double spend

The way parties achieve consensus should be able to change because users of enterprise blockchains operate under a diverse set of trust assumptions. Corda allows for “pluggable” consensus, whereas some platforms are locked to one consensus mechanism for the entire network. For example, parties can choose to use an algorithm called RAFT, which promises high speeds but assumes high levels of trust between parties. Conversely, the BFT algorithm runs at a lower speed but assumes lower levels of trust between parties.



What does decentralization mean?

Decentralization is a process of delegating the functions of one entity to many entities. The most significant difference between centralized and decentralized system is that a centralized system is often controlled, governed, and operated by a single entity. Blockchain technology can decentralize these – enabling entities to coordinate and agree upon information between each other, bilaterally or multilaterally without concentration of processes or data through a single intermediary.

Through a pre-agreed upon consensus algorithm, entities in a blockchain network can maintain collective records without trusting a third party. There also is not a need to retroactively reconcile information between disparate databases when a shared ledger ensuring a correct, current, consistent source of truth exists at all times.

The figure demonstrates the core differences between centralized and decentralized approaches in the context of a decentralized KYC utility. For a decentralized corporate KYC utility, a direct customer-to-bank relationship would remain, without a central operator maintaining the utility and controlling information flows. Third parties, such as attestors of certain identity characteristics, could sign off on relevant facts, but would not have a holistic view of a corporate customer's identity profile.

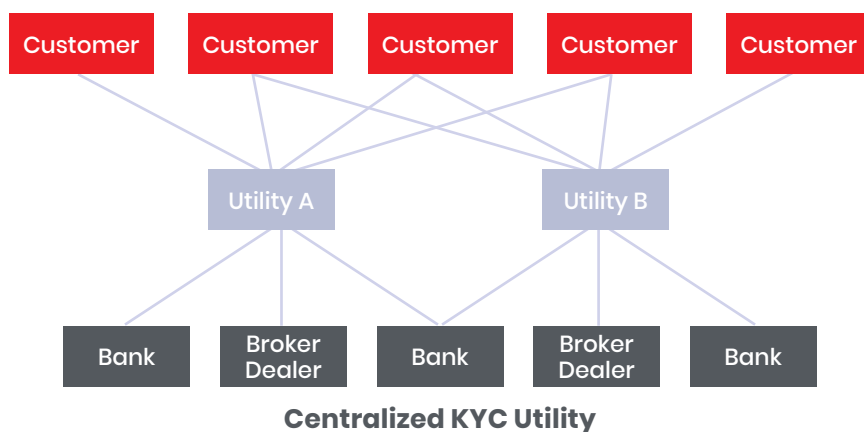
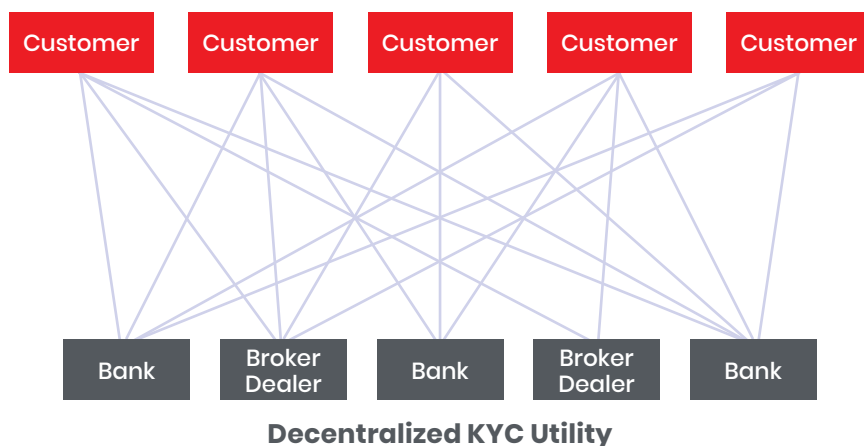

Much of the promise of blockchain technology involves decentralizing who operates and who governs a certain platform. However, no network using blockchain technology is entirely decentralized in all respects, and different blockchain networks have varying degrees of centralization and decentralization. For example, Bitcoin and Ethereum are examples of cryptocurrencies which are designed to be decentralized across the different spheres, but in some respects, are centralized.

Many enterprise use cases can benefit from more decentralization. A shift towards more decentralization can reduce the pains of new intermediaries, such as risk concentrations and a regulatory need to ensure these institutions do not evolve into rent-seekers or stifle innovation once established. In the context of corporate KYC, there may be advantages for decentralization across resiliency (no central point of failure), data security and privacy (avoidance of data "honeypots"), and process flexibility (customer-to-bank, instead of linear process dependencies on an intermediary).



What is interoperability?

Interoperability is the ability of different systems to work with each other. In computer systems, it involves the exchange and use of information. Interoperability in the enterprise context can happen at three levels:

- Integration of blockchain platforms with legacy systems
- Between different applications on the same platform
- Between different blockchain platforms

Historically, short-term and localized incentives for IT managers meant that IT departments across several industries often chose the fastest and cheapest ways to support a new product at the expense of holistic considerations for costs and complexity. As new products have been added they often do not interact smoothly with existing IT infrastructure. Corda was built in a way to allow flexibility for integration into these backend systems, and R3 works with large Enterprise Resource Planning (ERP)

providers that integrate their systems onto Corda business networks.

In the past, interoperability constraints between different products for financial institutions have limited how efficiently assets can be exchanged. Corda is built to allow CordDapps, applications built on Corda, to seamlessly interoperate with each other. By enabling interoperability within the platform, Corda delivers the vision of global interoperability initiated by public blockchains, but with the requirements of business. This stands in stark contrast to other enterprise blockchain platforms which must form “channels” or data siloes to achieve privacy. The architectural complexity of retroactively adding core privacy features, makes having multiple interoperating applications even within the same platform become very difficult for some platforms.

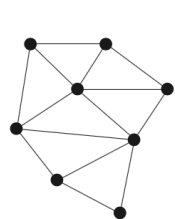

BITCOIN/ETHEREUM

- **RIGHT VISION:** Global interoperable network
- **WRONG DESIGN FOR ENTERPRISE:** Privacy, scalability, programming model wrong for enterprise

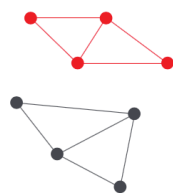

FABRIC/QUORUM

- **WRONG VISION:** Isolated silos with trapped assets
- **WRONG DESIGN FOR ENTERPRISE:** Privacy, scalability, programming model wrong for enterprise



c·rda

- **RIGHT VISION:** Global interoperable network
- **RIGHT DESIGN FOR ENTERPRISE:** Privacy, scalability, programming model designed for enterprise

An enterprise blockchain ecosystem with many different platforms would require architecturally intensive adaptations to allow cross-platform transactions and to align static data. Siloed communities without consistent standards would likely introduce many of the interoperability problems that blockchain technology promises to resolve. Traditional bridging across platforms through a third party may be possible, but such an approach could provoke novel breaks and counterparty risks (e.g. credit and operational). There are efforts across the R3 ecosystem to facilitate cross-platform interoperability, such as Project Indigo. The project allowed financial institutions on Corda to interact with the Sovrin network, a blockchain platform for self-sovereign identity.

Interoperability is a key aspect of the platform's design. Its applications and services run across Corda Network—a

common layer of identity, consensus and governance. This means businesses can transact openly and flawlessly with all their business partners, without trapped assets or islands of information.

As envisioned by R3 CTO Richard Gendal Brown, “The win comes when we break down silos; when we enable data and assets to move without friction; when we avoid duplication; when we eliminate reconciliations and unnecessary integrations.”

Corda and Corda Enterprise are fully interoperable, meaning companies using either can trade with one another, and that one organization can run both platforms seamlessly across different divisions. Corda also offers a smooth and direct migration path to Corda Enterprise if required.



Who is using Corda? What are some of the applications?

Over 300 financial institutions, regulators, trade associations, professional services firms and technology companies work to develop on Corda.

Corda optimizes at the industry level and brings the most value to an industry if market participants build interoperable solutions on the platform. In collaboration with R3 partners, R3 currently focuses on developing applications across five industry verticals.



RECENT PROJECTS IN DEVELOPMENT AND DEPLOYMENT INCLUDE:

- **Global Trade and Supply Chain**
 - **Marco Polo**: Open account trade finance application from TradeIX
 - **Voltron**: Documentary trade finance solution driven by banks across 4 continents from CryptoBLK
 - **Monetago**: A fraud mitigation network and commercial paper issuance application, in production in India and Latin America
 - **Ripe**: Trust and provenance in the end-to-end food supply chain
- **Capital Markets**
 - **Six Digital Exchange**: Regulated digital exchange being built on Corda to trade digital securities
 - **Tradewind**: Digitize and trade precious metals
 - **GuildOne**: Energy royalty smart contract, tokenization, execution and payment
 - **Finastra Lendercomm**: Enables lenders to see accurate information on-demand for syndicated loan portfolios
 - **HQLAx**: Improved collateral fluidity without requiring securities to move through CSDs. Regulator “DCR tracking view”, which reduces risk of fire sales and buys
- **Identity**
 - **Capgemini**: Decentralized KYC and identity data sharing for corporates and banks
 - **Gemalto**: Securing a trusted user’s identity through paired public and private keys
- **Cash & Settlement**
 - **Jasper**: Central bank assets (CAD) on a distributed ledger
 - **Finteum**: Global financial market for intraday borrowing
 - **SWIFT GPI Link**: The first integration of SWIFT GPI with Corda Settler to enable blockchain initiated payments to be tracked and settled on SWIFT
- **Insurance**
 - **B3I**: Application allowing a cedent to request a quote directly or with a broker
 - **Riskblock**: Consortium of insurers advancing applications such as proof of insurance, subrogation, data sharing and risk registries, and paramedic insurance
 - **ChainThat**: Brokers and reinsurers negotiate and manage terms for new risk contracts. Includes accounting, settlement and claims agreement
 - **EY Insurwave**: Marine hull insurance



How does Corda compare to Ethereum / Fabric?

Business considerations

	Corda	Fabric	Enterprise Ethereum
Company	R3	IBM	Several
Open-source	✓	✓	✓
Designed with end-user input	✓	✗	✗
Retail-focused architecture	✗	✗	✓

Network considerations

	Corda	Fabric	Enterprise Ethereum
Identity	Unique and legally valid real world identities	Certificate-based identity with no assurances that identity is related to real-world entity	No inherent notion of real-world identities
Scalability	Scalable as each node does not handle all transactions	Scalability limited by channels architecture, which increases exponentially with more participants	Low scalability due to mathematical complexities in zero knowledge proof privacy calculations

Transaction considerations

	Corda	Fabric	Enterprise Ethereum
Uniqueness	Pools of known notaries guarantee uniqueness	An ordering service guarantee uniqueness.	Validation nodes assure uniqueness most of the time
Privacy	Only participants to a transaction have access to the transaction data	Channels architecture allows for private transactions between counterparties	Private deployment of Ethereum (e.g. Quorum) has a viable privacy model
Conclusiveness	Completed transactions cannot be reversed	Completed transactions cannot be reversed	Small possibility completed transactions can be reversed

Legal considerations

	Corda	Fabric	Enterprise Ethereum
Legally binding agreements	Real-world legal prose can be linked to Corda assets	Network is not designed for any notion of data privacy or sovereignty	Transactions that has a possibility of being reversed creates legal ambiguity
Tamper-evident	Transactions are tamper-evident	Transactions are tamper-evident	Transactions are tamper-evident



What is Corda Settler?

Corda Settler is an **open source CorDapp** that allows Corda users to **settle payment obligations using any payment rail**, supporting cryptocurrencies or other crypto assets, and any traditional rail providing that it can report final settlement to a beneficiary. Corda Settler will initiate a payment and then verify that the beneficiary's account was credited with the expected payment, before automatically updating the Corda ledger. As development continues, we expect Corda Settler to be integrated with all common payment systems, both on- and off-blockchain platforms.

How it Works

When a payment obligation arises on Corda during the course of business, one party has the option to request settlement using an available payment rail, such as XRP, or SWIFT gpi. If needed, an Exchange Rate Oracle provides an FX rate that the parties can agree to use, in order to settle in a different currency. The payee updates the obligation with the payment instructions e.g. beneficiary account number.

The paying party is then notified that settlement has been requested, and that they must instruct a payment to the required account before the specified deadline. The payer uses the Settler to pay using the agreed rail and provides the Settlement Oracle with a transaction reference.

Once the Settlement Oracle confirms that the payment has arrived at the beneficiary's account, it updates the obligation on Corda to "settled".

Corda Settler

Beneficiary	Company A
Payer	Company B
Face Value	260 EUR
Due By	2018-12-04
Settlement Method	[address: ra6mzL1xy9aN5..., oracle: Settlement Oracle]
Status	Unsettled
Payments	[txID: 2E91FF59FID725..., amount: 260 EUR, status: SENT]
ID	b567bf99-98ce-4414-96ao...

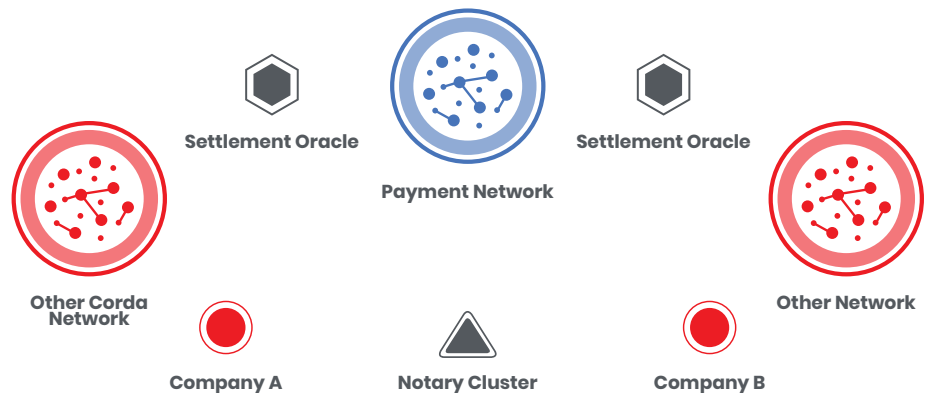

INTEGRATING CORDA SETTLER INTO THE WORKFLOW OF ANY APPLICATION MAKES SETTLEMENT EASY.

- Settle transactions on any payment rail:** Corda Settler is an open source CorDapp that can and will be integrated to all of the most-used payment systems, both on and off-blockchain platforms.
- Integrate with Ease:** With only two integration points required, Corda Settler is easy to integrate with existing payment applications and easy to work with.
- Move value onto Corda with confidence:** Go live with the applications on the blockchain platform built for business, knowing that the tools are in place to settle transactions on any other system, avoiding trapped liquidity and pre-funded accounts.
- Coordination between Corda and other systems:** CorDapp users need to make updates to assets and obligations on Corda based on activity on other platforms. Corda Settler provides a design pattern for developers to do this with ease.

Learn more at www.r3.com/recently-released/settler/



Continue the conversation

 r3.com

 [@inside_r3](https://twitter.com/inside_r3)

 medium.com/inside-r3

About this publication

This publication is intended for informational and educational purposes only and does not replace independent professional judgment or advice. No information contained in this publication is to be construed as legal advice. R3 does not assume any responsibility for the content, accuracy or completeness of the information presented or for any loss resulting from any action taken or reliance made on any information included in this publication.

About R3

R3 is an enterprise blockchain software firm working with a broad ecosystem of more than 300 participants across multiple industries from both the private and public sectors to develop on Corda, its open-source blockchain platform, and Corda Enterprise, a commercial version of Corda for enterprise usage.

The Corda platform is already being used in industries from financial services to healthcare, shipping, insurance and more. It records, manages and executes institutions' financial agreements in perfect synchrony with their peers, creating a world of frictionless commerce. Learn more at r3.com.