

A Comprehensive Survey of 6G Wireless Communications

Yang Zhao, *Graduate Student Member, IEEE*, Wenchao Zhai, *Member, IEEE*, Jun Zhao, *Member, IEEE*, Tinghao Zhang, *Graduate Student Member, IEEE*, Sumei Sun, *Fellow, IEEE*, Dusit Niyato, *Fellow, IEEE*, and Kwok-Yan Lam, *Senior Member, IEEE*

Abstract—While fifth-generation (5G) communications are being rolled out worldwide, sixth-generation (6G) communications have attracted much attention from both the industry and the academia. Compared with 5G, 6G will have a wider frequency band, higher transmission rate, spectrum efficiency, greater connection capacity, shorter delay, wider coverage, and stronger anti-interference capability to satisfy various network requirements. In this paper, we present a survey of potential essential technologies in 6G. In particular, we will give an insightful understanding of the paradigms and applications of the future 6G wireless communications by introducing index modulation (IM), artificial intelligence (AI), intelligent reflecting surfaces (IRS), simultaneous wireless information and power transfer (SWIPT), space-air-ground-sea integrated network (SAGSIN), terahertz (THz), visible light communications (VLC), blockchain-enabled wireless network, holographic radio, full-duplex technology (FD), Cell-Free Massive MIMO (CFmMM), and security and privacy problems behind technologies mentioned above.

Index Terms—6G, Wireless Communications, Survey, Index Modulation (IM), Artificial Intelligence (AI), Intelligent Reflecting Surfaces (IRS), Artificial Internet of Things (AIoT).

I. INTRODUCTION

As 5G communication networks are being deployed commercially [1], the academic and industry start working on developing 6G wireless communication systems. Currently, the rapid growth of data-centric intelligent systems has brought significant challenges to 5G wireless systems. For example, the haptic Internet-based telemedicine requires that the delay of air interface is less than 0.1 millisecond (ms) [2]. However, currently, it is only 1ms, which is still far from the standard. Compared with 5G, 6G has stricter demands in power consumption, reliability, privacy, security, etc. but provides better service quality (QoS) in data rate, latency, and coverage. 6G is considered a revolutionary generation of wireless communication because of the growing roles of intelligence, autonomy, context-awareness, ubiquitous, Internet of Everything (IoE), and collaboration in edge applications. 6G focuses on decentralized users' devices and edge infrastructure components instead of the centralized server used before [3,4].

Yang Zhao, Jun Zhao, Tinghao Zhang, Dusit Niyato and Kwok-Yan Lam are with School of Computer Science and Engineering, Nanyang Technological University, Singapore. (Email: s180049@e., junzhao, tinghao001@e., dnyato, kwokyan.lam}@ntu.edu.sg).

Wenchao Zhai is with College of Information Engineering, Jiliang University, Hangzhou, China. (Email: zhaiwenchao@cjlu.edu.cn).

Sumei Sun is with Institute for Infocomm Research (I2R), Agency for Science, Technology and Research (A*STAR), Singapore, and Infocomm Technology Cluster, Singapore Institute of Technology, Singapore. (Email: sunsm@i2r.a-star.edu.sg).

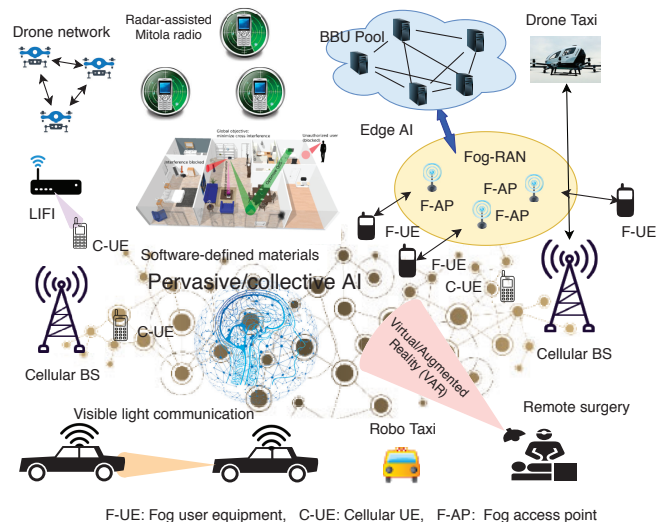

Fig. 1. The vision of 6G.

Fig. 1 illustrates emerging applications that will be enabled by 6G. 5G's ubiquitous mobile ultra-broadband, ultrahigh data density, and ultrahigh-speed-with-low-latency communications cannot fully support them [5]–[8]. To overcome the bottleneck of the existing wireless communication systems, various candidate technologies have been proposed. For example, to maintain the massive network of 6G, automation and intelligence should be widely implemented. AI is expected to enable a significant paradigm shift in 6G wireless networks, including machine learning, deep learning, etc. [3]. The spectral efficiency is also a key performance indicator, so IM and advanced full-duplex technologies are introduced. Although the connection density increases, the inter-user interference should not be influenced. Oppositely, the target should be limited to a lower threshold for a better user experience. Moreover, IRS may contribute to intelligent and active wireless communications paradigms, whereas IRS may help form the software-defined networking paradigm. Furthermore, to satisfy the target of broader coverage, 6G wireless communication networks use SAGSIN to accomplish the global coverage [9]. Because the consumption of the spectrum frequency is fast, 6G will undergo the transition from radio to sub-terahertz (sub-THz), VLC, and THz, which use higher ranges of frequencies [6,10]–[17]. To reduce the power consumption, SWIPT is proposed to prolong the span of the battery. The other

technology that can be used to manage and share the spectrum resource is blockchain, which can eliminate the central authority since the blockchains are untampered decentralized databases [18]. 6G is envisioned to support new services, for example, smart wearable devices, computing reality devices, autonomous vehicles, implants, sensing, and 3D mapping [5]. Finally, as data privacy becomes more critical, more security and privacy techniques will be explored.

Contributions. The contributions of this survey are summarized below.

- Current papers on 6G pay more attention to predicting technologies that may be used in the future, and few of them give a summary. While papers survey on 6G technologies only focuses on either network layer or physical layer. Our paper surveys almost all of the existing visions of 6G and summarizes them in detail, including both physical and network layer technologies. Furthermore, we give a deep insight into these existing technologies potentially utilized in 6G according to how these technologies satisfy the requirements of future 6G network, thus facilitating the understanding of their respective advantages comprehensively.
- We highlight some technologies that may be essential for 6G, including index modulation, artificial intelligence, intelligent surfaces, simultaneous wireless information, and power transfer, etc. Both advantages and challenges of these technologies are discussed in our manuscript, which gives the directions of future work for 6G applications. Based on the corresponding pros and cons, readers can explicitly improve specific technology for targeted application scenarios.
- Not only the principles of the technologies themselves are presented, but their variations are also provided. For example, its relative variations such as STSK and GSTSK are also discussed briefly for the TD-SM technique. After that, readers can have a comprehensive understanding of these technologies and their evolution in solving more and more complex problems.
- Applications of existing potential 6G technologies are also investigated in our manuscript. By summarizing the applications in various scenarios, we help recognize the 6G network's differences from its 5G counterpart. Therefore, it is easy to have an exact blueprint for the development of a future network.

Organization. The rest of paper is organized as follows. Section II gives an overview of emerging technologies that enable the paradigm shift in 6G wireless networks. From Section III to Section VIII-G, we present each technology of 6G in detail. Section IX discusses potential security and privacy problems existing in 6G. Section X lists some applications enabled by 6G technologies. Section XI concludes this paper.

Notations. For sake of convenience, we give an illustration of the notations used throughout our manuscript. Bold letters denote vector and bold capital letters denote matrix. $\|\cdot\|_F$ represents the Frobenius norm of a matrix. $|\cdot|$ is the magnitude of a complex number. $\lfloor \cdot \rfloor$ denotes the largest integer that is smaller than the argument. $\binom{\cdot}{\cdot}$ is the binomial

coefficient. $\text{diag}(\cdot)$ is the diagonalize operation of a matrix. The subscripts $(\cdot)^T$, $(\cdot)^*$, and $(\cdot)^H$ define the operation of transpose, conjugate, and Hermitian transpose, respectively. \mathbf{I}_N represents an N -by- N identity matrix. Table I summarizes abbreviations used in this paper.

II. AN OVERVIEW OF 6G TECHNOLOGIES

6G is expected to outperform 5G in multiple specifications which can be summarized into six aspects as shown in Fig. 1, including frequency, individual data rate, peak data rate, core network, mobility, and latency. From which, we can see that 6G requires lower latency, higher frequency and data rate, faster mobility, and broader applications. More specifically, Table II lists details of each expected requirement.

In this section, we will present an overview of the most eye-catching ideas pertaining to 6G, including index modulation (IM), artificial intelligence (AI), intelligent surfaces, simultaneous wireless information and power transfer (SWIPT), terahertz (THz), visible light communication (VLC), device to device (D2D), full-duplex (FD), Cell-Free massive MIMO (CFmMM), space-air-ground-sea integrated network (SAGSIN), blockchain-based network, network in box, and holographic radio [19]–[26]. Besides, we will introduce potential applications and discuss security and privacy problems in above technologies.

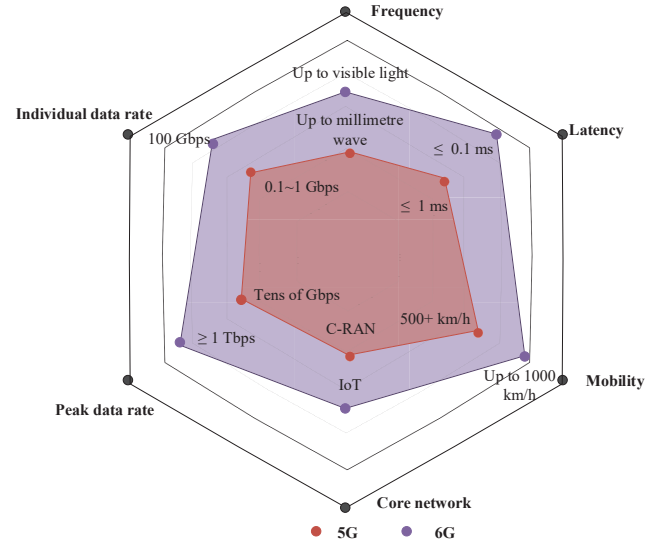

Fig. 2. Qualitative comparison between 5G and 6G communications. The comparison, which is speculative, is made in terms of: security, secrecy and privacy; spectral efficiency; intelligence; energy efficiency; and affordability and customization [19].

IM. IM improves the transmission rate, which is potential to be used in 6G. Chau *et al.* [28] suggest that information bits can be transmitted through the index of the antennas in MIMO systems. They name such a technique as space shift keying (SSK) and combine the SSK with classical linear modulation, amplitude-phase modulation (APM), for example, and space modulation (SM) is proposed based on the same idea in SSK.

TABLE I
TABLE OF ABBREVIATIONS.

5G	Fifth generation
6G	Sixth generation
IM	Index Modulation
IoE	Internet of Everything
SWIPT	Simultaneous Wireless Information and Power Transfer
AI	Artificial Intelligence
IRS	Intelligent Reflecting Surfaces
LIS	Large Intelligent Surfaces
THz	Terahertz Communications
VLC	Visible Light Communication
D2D	Device-to-Device Communication
CFmMIMO	Cell-Free Massive MIMO
SAGSIN	Space-Air-Ground-Sea Integrated Network
NIB	Network in Box
AIoT	Artificial Internet of Things
mMIMO	massive multiple input multiple output
FD	Full-duplex
APM	Amplitude Phase Modulation
PSK	Phase-Shift Keying
QAM	Quadrature Amplitude Modulation
ML	Maximum Likelihood
SD-IM	Spatial-Domain IM
SSK	Spatial Shift Keying
FD-IM	Frequency-Domain IM
(G)TD-IM	(Generally) Time-Domain IM
CD-IM	Channel-Domain IM
(G)SM	(Generally) Spatial modulation
OFDM	Orthogonal Frequency Division Multiplexing
(G)SIM-OFDM	(Generally) Subcarrier-Indexed OFDM
DM-OFDM	Dual Mode Index-aided OFDM
TDD	Time Division Duplex
PPM	Pulse Position Modulation
(G)STSK	(Generally) Space-Time Shift Keying
RF	Radio Frequency
(D)MBM	(Differential) Media Based Modulation
STBC	Space-Time Block Code
PSM	Precoding SM
TCM	Trellis-Coded Modulation
RSM	Received SM
ZF	Zero Forcing
MMSE	Minimum Mean Square Error
DSM	Differential SM
CSI	Channel State Information
MM-OFDM	Multiple Mode SIM-OFDM
QIM	Quadrature IM
SCMA	Sparse Code Multiple Access
NOMA	Non-Orthogonal Multiple Access
BICM	Bit-Interleaved Coded Modulation
UM-MIMO	Ultra-Massive MIMO
LIM	Large Intelligent Metasurface
SDS	Software-Defined Surface
SDM	Software-Defined Metasurface
EM	Electromagnetic
QoS	Quality of Service
BS	Base Station
UE	User Equipment
SINR	Signal-to-Interference-Plus-Noise Ratio
BER	Bit-Error Rate
HD	Half-Duplex
RFID	Radio Frequency Identification
TS	Time Switching
PS	Power Splitting
SIC	Successive Interference Cancellation
SER	Symbol Error Rate
PEP	Pairwise Error Probability
SNR	Signal-to-Noise Ratio

TABLE II
REQUIREMENTS AND FEATURES OF 6G [4,7,19,27].

Requirements	6G
Service types	MBRLLC/mURLLC/HCS/MPS
Service level	Tactile
Device types	Sensors and DLT devices/CRAS/ XR and BCI equipment/Smart implants
Jitters	1 usec
Individual data rate	100 Gbps
Peak DL data rate	≥ 1 Tbps
Latency	0.1 msec
Mobility	up to 1000 km/h
Reliability	up to 99.99999%
Frequency bands	- sub-THz band - Non-RF, e.g. optical, VLC, laser . . .
Multiplexing	Smart OFDMA plus IM
Power consumption	Ultra low
Processing delay	≤ 10 ns
Maximum rate	100Gb s^{-1}
Security and privacy	Very high
Network orientation	Service-centric
Wireless power transfer /Wireless charging	Support (BS to devices power transfer)
Smart city components	Integrated
Autonomous V2X	Fully
Localization precision	1 cm on 3D
Architecture	Intelligent Surface
Core network	Internet of Everything
Satellite integration	Full
Operating frequency	1 THz
Highlight	Security, secrecy, privacy
Multiplexing	Smart OFDMA plus IM

In SM technology, the source information bits are divided into two parts: the index of the transmit antennas, and the other part for the APM. Therefore, SM can significantly increase the transmission rate by sending the spare information bits through the antenna index and the traditional APM transceiver. Apart from the antennas, other resource entities can also be indexed to transmit the additional information bits. These resource entities include time slots, sub-carriers, and channel state. Also, this class of modulation, where the spare information bits are transmitted through the index of resources, is called index modulation. Orthogonal frequency division multiplexing access (OFDMA) plus IM will be essential technologies to significantly increase the throughput to support more users to access the 6G network.

AI. Artificial intelligence (AI) provides intelligence and automation to wireless networks by imitating human thought processes and intelligent behaviours. Thus, AI is the key technology in 6G wireless communication systems since 6G is envisioned to offer full automation based on AI. AI benefits in circumventing signal processing's complex processes, such as joint optimization in network design, resource management, and resource allocation. The smart society has attracted the es-

sential attention of researchers from the academia and industry. A variety of smart society functions should be implemented through AI technologies, such as smart wearable devices, intelligent robots, etc. Also, AI-empowered 6G alters the way how a complex target job is performed, and it reduces the latency of the wireless systems, especially for unmanned aerial vehicle (UAV) scenarios in which ultra-low latency is demanded; AI reduces the processing time to a great extent. In the tasks of channel estimation [29] and network slicing [30], where the signal processing is severely time-consuming, AI can replace the classical manner of operation to increase the efficiency and decrease the latency.

Intelligent Surfaces. There are two kinds of intelligent surfaces, including large intelligent surface (LIS) and intelligent reflecting surface (IRS). The concept of deploying antenna arrays as LISs in massive MIMO systems is initially proposed by Hu *et al.* in [31,32]. Compared with the beamforming technology where a large number of antennas are required to make the signals focused, LISs are electromagnetically active in the physical environment, and impose little restrictions on how antennas spread. Therefore, LISs can avoid the adverse effects of antenna correlations. However, due to the active property of the surfaces, LISs consume a lot of power resources and are not power efficient.

To overcome the shortness of power consumption, passive IRS is proposed by Wu *et al.* [33] to replace the active antennas used by LISs. IRSs are considered to tune the wireless environments to increase the spectrum and energy efficiency while consuming little power. Therefore, by controlling the reflection characteristics of the incident waves in a deliberate manner, the signal quality can be improved significantly. With the above advantageous features, IRS is considered as a promising candidate technology for 6G. LIS and IRS both utilize intelligent surfaces to enhance the signal quality at the receiver, and they not only improve the data rate but also broaden the coverage of the network.

SWIPT. 6G is supposed to be a complex network where a large variety of smart devices are accessed to the system and are required to communicate with others at anytime, and the lifetime of the battery-charging modules is also required to fulfill the constraints of ultra-low power consumption as listed in Table II. To prolong the life span of various devices in the network, simultaneous wireless information and power transfer (SWIPT) technology is proposed. SWIPT enables sensors to be charged exploiting wireless power transfer; thereafter, battery-free devices can be supported in 6G, reducing the power consumption of the network substantially [34]. Zhang *et al.* [35] describe SWIPT technology from the perspective of a scientific hypothesis and engineering practice in detail. Subsequently, in [36]–[39], performance on the outage probability, throughput, and sum rate for non-orthogonal multiple access (NOMA) networks with SWIPT are derived. Bariah *et al.* [40,41] first conduct error probability analysis of the NOMA-based networks with SWIPT. The error probability performance of SWIPT is severely affected by the power splitting factor, which provides a principle for designing the SWIPT system in practical engineering.

THz. Terahertz (THz) is one of the potential technologies

for the 6G wireless communications [6,11]–[15], because the fact that past generations of wireless networks utilize micro-wave communications over the sub-6 GHz band, whose resources are almost used up [15]. Due to the propagation loss, the THz will be used for high bit-rate short-range communications [16]. Besides, the 90-200GHz spectrum is often not used in the past generations of wireless networks. The sub-THz radio spectrum above 90GHz has not been exploited for radio wireless communications yet; thus, it is envisioned to support the increased wireless network capacity [17]. 6G will undergo the transition from radio to sub-terahertz (sub-THz), visible light communication, and THz to support explosive 6G applications [10]. Therefore, ultra-high bandwidth requirement can be satisfied through THz communications, and the transmission rate can reach the magnitude of Tbps. THz and VLC improve the data rate by transmitting the signals at a high frequency band that is not used previously. Subrt *et al.* [42] propose to enhance the capacity by transmitting the signals through intelligent walls, where active frequency selective surfaces are utilized to control the signal coverage for the first time. Due to the propagation loss, THz will be used for high bit-rate short-range communications.

VLC. Visible light communication (VLC) uses visible light between 400 and 800 THz (780–375 nm) to communicate information. It provides ultrahigh bandwidth (THz), zero electromagnetic interference, free abundant unlicensed spectrum, and very-high-frequency reuse [43]. Therefore, VLC helps to develop the short range communications of 6G networks [44]. Besides, 1G-5G wireless networks have utilized micro-wave communications over the sub-6 GHz band, whose resources are almost used up [15]. Correspondingly, since more smart devices are integrated into the network and an explosive growth appears for the area traffic capacity, the high capacity becomes an essential requirement of 6G. To fulfill the requirement of capacity or data rate, VLC technologies are potentially to be used in 6G.

D2D. Device-to-Device (D2D) communication is defined as the direct communication between devices without going through base stations and the communication can be done under licensed (i.e., cellular network) or unlicensed spectrum [45,46]. D2D improves the throughput, energy efficiency, delay, and fairness of the communication [47,48]. As the number of edge devices is explosively increasing, D2D is gaining more attention and getting more widely implemented [49].

FD. A communication system involves both the sender and the receiver. Under the full-duplex mode, both the sender and receiver can send simultaneously. Compared with half-duplex, where either the sender or the receiver works at a period of time, full-duplex is more efficient.

CFmMM. Cellular wireless networks are based on cellular topologies. An area is then divided into multiple cells according to the topologies, and each cell is served by one base station. The drawback of cell-based wireless network is that if the device is at the edge the cell, its signal is pretty weak. By tackling the low communication ability at the edge of the cell, the Cell-Free Massive multiple-input-multiple-output (CFmMM) concept is proposed which removes the cells of the network. The idea of CFmMM means that one device is no

longer attached to a single base station instead all base stations coherently serve the device in an area.

SAGSIN. 6G wireless communication networks will integrate space-air-ground-sea networks to achieve the global coverage [9], i.e., 6G will construct a space-air-ground-sea integrated network (SAGSIN). As expected in the white paper released in January 2020, the 6G network should cover environments, including sky (10,000km) and sea (20 nautical miles) [50]. By integrating the three networks together, SAGSIN can cope with various users and services' growing traffic demands.

Blockchain-based Network. Blockchains are distributed databases which are constructed based on the theory of the hash tree, and they are tamper-proof and hard to reverse [18]. Blockchains have attributes like auditability, data integrity, and transparency [51]. Thus, blockchains can be used to manage spectrum resources without using a centralized authority. Besides, blockchains are also suitable to protect data's security and privacy or control access. Fan *et al.* [52] propose an efficient and secure blockchain-based privacy-preserving scheme, combining access policy, and encryption technology to guarantee data privacy. Kotobi *et al.* [53] use blockchain as a decentralized database to improve the access protocols and secure spectrum sharing in mobile cognitive radio networks. Yang *et al.* [54] present a trusted authentication architecture based on blockchain for could radio over a fiber network.

Security and Privacy. In 6G, every edge device will be connected to the Internet. Paying attention to edge computing, 6G uses artificial intelligence and big data mining technology to adapt to different application and targets. As the key technology used in 6G networks, artificial intelligence will help achieve the Internet of Everything (IoE). In IoE, data are unevenly distributed among a lot of edge devices such as mobile phone, wearable devices, and vehicles, and edge devices which can train and store the data themselves without sharing the training data, while they need to contribute to the shared models. Moreover, it should conduct data abstraction and reduce data dimensionality since it is not feasible to store massive monitored data for a long time [55]. Some security and privacy issues come with AI; for example, attackers masquerading as legitimate users can upload poisoned data to corrupt the whole model. Akhtar *et al.* [56] investigate the adversarial attacks against deep learning models and show how the attacks happen in practice, whereas some other security and privacy issues are identified in [57]. Lovén *et al.* [3] identify the challenges of edge AI, and aims to improve edge computing and AI-based approaches security via security systems. Zhou *et al.* [58] combine deep learning and edge computing, developing robust mobile crowdsensing that can conduct data validation and local processing. Sattiraju *et al.* [59] analyze the feasibility of utilizing machine learning techniques such as recurrent neural networks in the physical layer and propose an unsupervised learning algorithm to improve the physical layer security. AI promotes the development of 6G networks while brings a lot of security and privacy issues. How to handle this double-edged sword, combing the advantages of AI and security will still be a research focus soon.

Applications. Empowered by 6G, a wide range of AI

applications will evolve into "connected intelligence" [60], hence facilitating every aspect of our daily life. For example, advanced AI approaches can be employed in network management or autonomy to save manpower [3,4]. In addition, 6G revitalizes smart healthcare by providing real-time health monitoring [61], high-precision medical treatment [11], and reliable privacy protection [27]. With the advent of 6G, Industry 4.0 will be fully realized as smart manufacturing will achieve high-precision manufacturing [62]. Intelligent robots connected by ubiquitous 6G network enable manufacturing systems to carry out complex and dangerous tasks without risking people's life [61]. Moreover, smart home equipped with intelligent IoT devices will offer comfortable living environment to people [63], and 6G allows smart home to ensure the residents security. In terms of traffic and transportation, sophisticated sensing and planning algorithms can be deployed for traffic optimization [63]. Other applications, such as smart grid [64] and unmanned aerial vehicle [65], will also be enhanced with the aid of 6G.

III. INDEX MODULATION

Index Modulation (IM) is a kind of modulation scheme that sends extra information bits through resource entities' index. On the one hand, high capacity can be achieved due to the spare information bits' transmission. On the other hand, because the sending of these spare bits does not consume any power and spectrum resources, IM has both high spectral efficiency and high energy efficiency simultaneously compared with its non-IM-aided counterpart. The structure of the IM system is depicted in Fig. 3. As shown in the figure, at the transmitter, the information bits are divided into two parts after the operation of serial to parallel conversion, one part for the classical amplitude phase modulation (APM) such as phase-shift keying (PSK) or quadrature amplitude modulation (QAM), etc., and the other part for the activation of the index resources exploited for transmitting the modulated APM signals. After the up-conversion, passband modulated signals are transmitted through the activated resource entities. At the receiver, down-conversion is first performed to convert the received signals to baseband. An index demodulator is carried out to detect the information bits used for APM and index activation of resource entities. Finally, a parallel to series conversion is conducted to recover the original information sequence. The basic IM demodulator is a maximum likelihood (ML) detector. However, the complexity of the ML detector increases exponentially with the number of resource entities. Such high complexity makes ML detector infeasible in practical implementation with a large number of resource entities. Therefore, reduced-complexity algorithms such as a greedy algorithm, log-maximum a posteriori (Log-MAP) algorithm, etc., are explored.

According to the categories of the resource entities used for index selection, IM can be classified into spatial-domain IM (SD-IM), frequency-domain IM (FD-IM), time-domain IM (TD-IM), and channel-domain IM (CD-IM). Each kind of IM scheme has its characteristics.

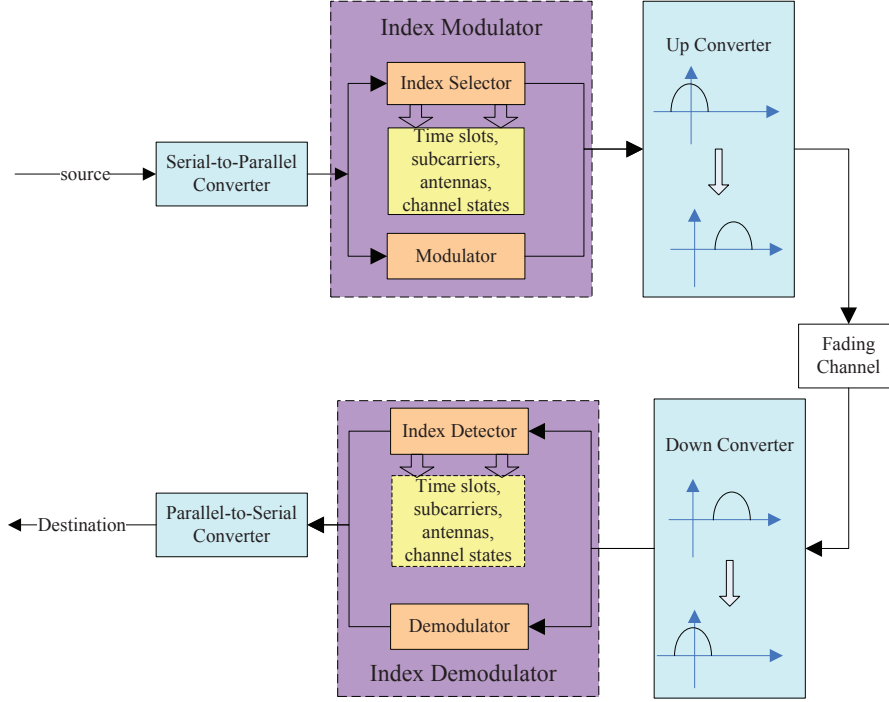

Fig. 3. The structure of IM-aided systems.

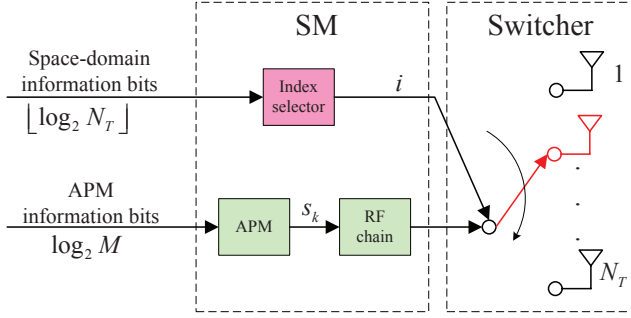

Fig. 4. The structure of SM systems.

SD-IM. SD-IM is also called spatial modulation (SM), where the spare information bits are used to activate the transmit antennas [66]. Compared with MIMO systems, SM does not need inter-antenna synchronization and is free of inter-antenna interference, which leads to low receiver complexity. The structure of SM is shown in Fig. 4. Assume the number of transmit antennas and the receive antennas are N_T and N_R , respectively. At the transmitter, $\lfloor \log_2 N_T \rfloor$ bits are used to decide which antenna is activated, and $\log_2 M$ bits are transformed to choose the M -ary APM symbols. Therefore, the data rate of SM in terms of bits per channel use (bpcu) can be computed as

$$R_{SM} = \lfloor \log_2 N_T \rfloor + \log_2 M \text{ (bpcu)}. \quad (1)$$

Assume the i th antenna is activated and the modulated APM symbol is s_m ($i = 1, 2, \dots, N_T; m = 0, 1, \dots, M - 1$). After passing through the fading channel, the received signal can be written as

$$\mathbf{y}_{SM} = \mathbf{H}_s \mathbf{x}_{SM} + \mathbf{n}, \quad (2)$$

where $\mathbf{y}_{SM} \in \mathbb{C}^{N_R \times 1}$ is the received signal vector; $\mathbf{H}_s \in \mathbb{C}^{N_R \times N_T}$ is the fading channel matrix of SM system whose elements are independent and identically distributed complex Gaussian random variables with zero-mean and unit variance; $\mathbf{n} \in \mathbb{C}^{N_R \times 1}$ is the additive white Gaussian noise (AWGN); and $\mathbf{x}_{SM} \in \mathbb{C}^{N_T \times 1}$ is the transmit vector represented by

$$\mathbf{x}_{SM} = \underbrace{[0, \dots, 0]}_{i-1}, s_m, \underbrace{[0, \dots, 0]}_{N_T-i} \quad (3)$$

When the modulation alphabet $M=1$, SM can also be named as SSK where all the source information bits are conveyed through the index of the activated antenna. The SM can also be extended to general SM (GSM) to improve the data rate when multiple antennas are activated to transmit the modulated signals (i.e., GSM systems are researched for higher capacity). Fig. 5 depicts the structure of GSM. Compared with SM, K RF chains exist simultaneously. Hence, the number of information bits for index selection and APM symbols are $\left\lfloor \log_2 \binom{N_T}{K} \right\rfloor$ and $K \log_2 M$, respectively. Denote the vector of activated antennas as $\mathbf{j} = (j_1, \dots, j_K)^T$, ($j_k \in 1, \dots, N_T$), and then the received signal for GSM system has the same expression with Eq. (2):

$$\mathbf{y}_{GSM} = \mathbf{H}_s \mathbf{x}_{GSM} + \mathbf{n}, \quad (4)$$

where the transmitting block is expressed as

$$\mathbf{x}_{GSM} = [x_1, \dots, x_{N_T}]^T \quad (5)$$

with

$$x_n = \begin{cases} s_m & n = j_k \\ 0 & n \notin \mathbf{j} \end{cases} \quad n = 1, 2, \dots, N_T. \quad (6)$$

The data rate of GSM is

$$R_{\text{GSM}} = \left\lfloor \log_2 \left(\frac{N_T}{K} \right) \right\rfloor + K \log_2 M. \quad (7)$$

At the receiver, ML algorithm is generally exploited to estimate the transmitted source information. The ML detector is expressed as

$$\hat{\mathbf{x}}_{(\text{G})\text{SIM}} = \arg \min \|\mathbf{y}_{(\text{G})\text{SIM}} - \mathbf{H}_s \hat{\mathbf{x}}_{(\text{G})\text{SIM}}\|^2. \quad (8)$$

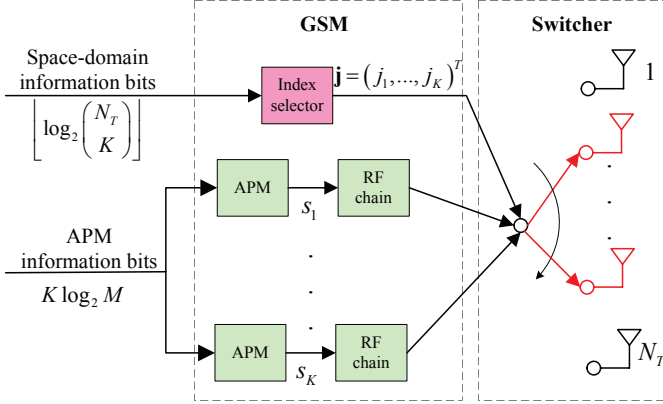

Fig. 5. The structure of GSM systems.

By searching all the possible activated antennas and APM symbols exhaustively, ML detector has the complexity of $\mathcal{O}(M^t)$ while $t = \binom{N_T}{K}$ is the possible scenario of activated transmit antennas. The detecting complexity of ML is considerably high when the number of antennas is large, which limits the practical implementation for large-scale MIMO systems. Therefore, a lot of researchers focus on the algorithms for low-complexity detector. The principle of reducing the complexity is basically to decouple the detection of activated antennas and modulation symbols. This two-step detection algorithm first determines the index of the activated antennas, and then demodulates the APM symbols on the detected transmit antennas [67]–[70]. For example, the compressed sensing (CS) based detection algorithm exploits the sparse property of the activated antennas among the overall transmit antenna set to detect the index for activation [71]–[73]; the sphere decoding based detection algorithm detects the activated antennas iteratively [74,75]; the ordered block minimum mean-squared-error (OB MMSE) based detection algorithm sorts the soft decisions of the active antenna combination and choose the largest K decisions for estimation in GSM systems [76,77], etc. These algorithms can reduce the complexity of the detection at the expense of performance degradation.

FD-IM. The orthogonal frequency division multiplexing (OFDM) technique is widely used due to its high spectral efficiency in 4G and 5G communications and will still be used in 6G. The bandwidth is divided into several subcarriers orthogonally, and each subcarrier transmits its own data bits individually. For the FD-IM technique, additional bits are used to choose the indices of the activated subcarriers. Therefore, FD-IM is also called subcarrier-indexed OFDM (SIM-OFDM). Suppose an OFDM system consists of L subcarriers which are

uniformly divided into G groups, and each group contains $P = L/G$ subcarriers. For each group, one subcarrier is activated and L bits are needed for index selection while $G \log_2 M$ bits are transmitted for M -ary APM symbols in a OFDM block. The SIM-OFDM system can also be extended to generally SIM-OFDM (GSIM-OFDM) system just the same as GSM when K subcarriers are activated for each group. The structure of GSIM-OFDM is depicted in Fig. 6.

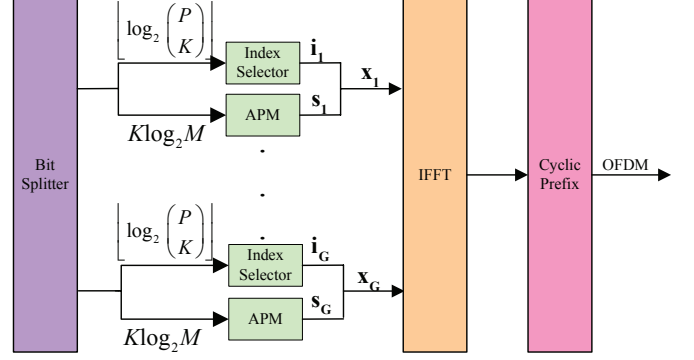

Fig. 6. Structure of IM system.

In Fig. 6, \mathbf{i}_g is the subcarrier index vector for group g ($g \in \{1, 2, \dots, G\}$), and can be expressed as

$$\mathbf{i}_g = (i_g^1, \dots, i_g^K)^T, i_g^k \in \{1, 2, \dots, P\}. \quad (9)$$

The vector of APM symbols for group g is

$$\mathbf{s}_g = (s_g^1, \dots, s_g^K)^T. \quad (10)$$

Accordingly, for group g , the frequency-domain subcarrier vector $\mathbf{x}_g = (x_g^1, x_g^2, \dots, x_g^P)^T$ is

$$x_g^p = \begin{cases} s_g^k & p = i_g^k \\ 0 & n \notin \mathbf{i}_g \end{cases} \quad p = 1, 2, \dots, P. \quad (11)$$

The transmitted frequency-domain OFDM signal block is written as

$$(\mathbf{G})\text{SIM} = (\mathbf{x}_1^T, \dots, \mathbf{x}_G^T)^T. \quad (12)$$

The expression for received signal of (G)SIM-OFDM system is (without cyclic prefix)

$$\mathbf{y}_{(\text{G})\text{SIM}} = \mathbf{H}_F \mathbf{F}_L^H \mathbf{x}_{(\text{G})\text{SIM}} + \mathbf{n}, \quad (13)$$

where $\mathbf{y}_{(\text{G})\text{SIM}} \in \mathbb{C}^{L \times 1}$ is the time-domain received signal after removing the cyclic prefix, and \mathbf{F}_L is the $L \times L$ Fourier transform matrix.

The transmission rate of GSIM-OFDM is

$$R_{\text{GSIM-OFDM}} = \frac{G \left(\left\lfloor \log_2 \left(\frac{P}{K} \right) \right\rfloor + K \log_2 M \right)}{L + L_{CP}} \text{ (bpcu)}, \quad (14)$$

where L_{CP} is the length of the cyclic prefix.

From Eq. (14), we know that the number of index bits is only proportional to the logarithm of the group size P . However, compared with the conventional OFDM system whose APM symbol bits number is proportional to the size of subcarriers L , GSIM-OFDM has no advantage in transmission rate when the number of subcarriers L is large

while the activated number K is small. Ishikawa *et al.* [78] demonstrate that GSIM-OFDM outperforms the conventional OFDM system when the spectral efficiency of the system is lower than 2bit/s/Hz. To overcome the shortness of under-utilization of subcarriers, Mao *et al.* propose a dual-mode IM-aided OFDM (DM-OFDM) system which fully exploits the subcarrier resources to convey the source information while the diversity gain of IM system is maintained as well [79]. In DM-OFDM system, all the subcarrier resources are used for transmitting the APM symbols for each group $g(g = 1, \dots, G)$. However, two distinguishable constellation alphabets \mathcal{M}_A and \mathcal{M}_B with the sizes of M_A and M_B are used for modulation. Additional bits are conveyed to select the K subcarriers which are modulated by alphabet \mathcal{M}_A , and the other $P - K$ subcarriers are modulated through APM symbols in alphabet \mathcal{M}_B . Therefore, the data rate for DM-OFDM in terms of bpcu is

$$R_{\text{DM-OFDM}} = \frac{G}{L + L_{\text{CP}}} \times \left(\left\lfloor \log_2 \left(\frac{P}{K} \right) \right\rfloor + K \log_2 M_A + (P - K) \log_2 M_B \right) \quad (\text{bpcu}). \quad (15)$$

By comparing Eq. (14) and Eq. (15), we find that the throughput of the DM can be improved to a great extent when all the subcarrier resources are exploited. However, because \mathcal{M}_A and \mathcal{M}_B are required to be distinguishable, it should be designed as $\mathcal{M}_A \cap \mathcal{M}_B = \emptyset$. A feasible method for designing the constellation is to divide a QAM alphabet of size $(\mathcal{M}_A + \mathcal{M}_B)$ into two subsets [79,80].

TD-IM. Time Division Duplex (TDD) is one of the generally used wireless techniques. In TDD transmission, a data frame consists of several time slots, and each time slot can be used to transmit source information. The earliest concept of TD-IM can date back to 1977 when a scheme called pulse-position modulation (PPM) is proposed [81]. In a PPM system, a symbol duration is partitioned into N_p slots, where only one slot is activated according to the information selection while the others are kept empty. PPM has the same idea of SSK, and TD-SM has the same structure of SM as well. For convenience, we assume that N_{ns} represents the number of all the time slots, and only one is activated just as the SM system. If the number of activated time slots K is greater than one (i.e., $K > 1$), TD-IM system can also be extended to generally TD-SM (GTD-SM). Therefore, the data rate of GTD-SM in terms of bpcu is computed as

$$R_{\text{GTD-IM}} = \frac{\left\lfloor \log_2 \left(\frac{N_{ns}}{K} \right) \right\rfloor + K \log_2 M}{N_{ns}} \quad (\text{bpcu}). \quad (16)$$

To further exploit the characteristics of IM, the space-time shift keying (STSK) technique is proposed by Sugiura *et al.* [82], and they combine TD-IM and space-time block code (STBC) together for index selection. Subsequently, they extend STSK to a general format (GSTSK) in [83], where indices of multiple activated dispersion matrices are chosen based on the transmission information bits, further improving the capacity. The structure of GSTSK is depicted in Fig. 7.

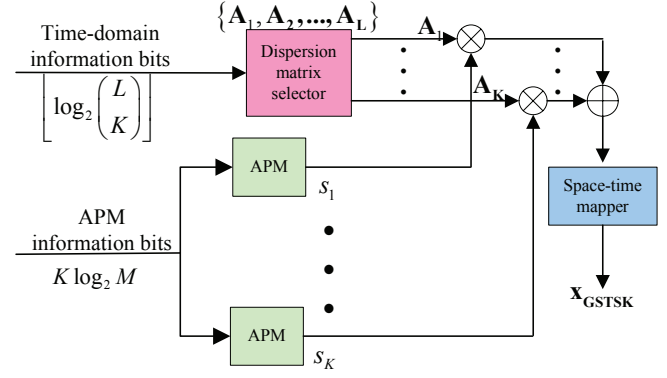

Fig. 7. Structure of GSTSK system.

In Fig. 7, $\{\mathbf{A}_1, \dots, \mathbf{A}_L\}$ is the pre-defined dispersion matrix set with $\mathbf{A}_l (l = 1, \dots, L) \in \mathbb{C}^{N_T \times N_{ns}}$ the space-time matrix. Therefore, $\left\lfloor \log_2 \left(\frac{L}{K} \right) \right\rfloor$ bits are transmitted to select K ones for space-time mapper. On the other hand, $K \log_2 M$ bits are used for symbol modulation, where K symbols are multiplied to the K dispersion matrices, respectively. The signal for transmission can be expressed as

$$\mathbf{x}_{\text{GSTSK}} = \sum_{k=1}^K s_k \mathbf{A}_k. \quad (17)$$

The transmission rate for STSK is

$$R_{\text{GSTSK}} = \frac{\left\lfloor \log_2 \left(\frac{L}{K} \right) \right\rfloor + K \log_2 M}{N_{ns}} \quad (\text{bpcu}). \quad (18)$$

CD-IM. Unlike the aforementioned IM schemes, CD-IM can change the property of radio frequency (RF) environment by employing RF mirrors or electronic switches [84]–[87]. Therefore, CD-IM has also named media based modulation (MBM). MBM uses several RF mirrors/electronic switches around the transmit antennas. It allows the signal to transmit to the receiver through distinct channel paths according to the on/off status of the RF mirrors/electronic switches. Compared with the MIMO systems, the channel matrix is generally non-orthogonal, and MBM can further randomize the channel by perturbing the wireless environment, enhancing the achievable rate. MBM can be combined with MIMO systems (MIMO-MBM) [84,85], Alamouti STBC systems (STCM) [87], etc., to improve the capacity further or detect performance. In addition, MBM has higher transmission rate due to the fact that the number of additional bits increases linearly with the number of RF mirrors whilst in SM system the number only increases with the logarithm with the number of transmit antennas. Moreover, to guarantee the independence between RF chains, the distance between neighbouring antennas must be large enough while no such constraint is required in deployment for RF mirrors. Assume there are m_r mirrors around each transmit antenna, and the set of the overall channel states for the c th antenna is

$$\mathbf{H}^{(c)} = \left\{ \mathbf{h}_1^{(c)}, \dots, \mathbf{h}_{2^{m_r}}^{(c)} \right\}, \quad (19)$$

where $\mathbf{h}_n^{(c)} \in \mathbb{C}^{N_r \times 1}$, ($c = 1, \dots, N_T; n = 1, \dots, 2^{m_r}$) is the channel realization of the c th single-input multiple-output (SIMO) RF chain. Suppose for the c th SIMO RF chain the corresponding APM symbol is $s_k^{(c)}$, and then the received signal can be expressed as

$$\mathbf{Y}_{\text{CD}} = \sum_{c=1}^{N_T} s_k^{(c)} \mathbf{h}_n^{(c)} + \mathbf{n}. \quad (20)$$

The rate transmission is

$$R_{\text{CD}} = N_T \log_2 M + N_T m_r (\text{bpcu}). \quad (21)$$

To have an explicit review of how the existing IM schemes improve the capacity, we depict the comparison of the transmission rate for different IM schemes in Table III.

Other IM Techniques. Apart from the fundamental technologies introduced above, we would like to introduce following IM-related applications. In wireless environments where the fading channels are spatially-correlated, the detection performance will suffer from considerable degradation as the channel impulse responses are very similar, especially when the transmit antennas are closely deployed. To solve the problem, the precoding SM (PSM) scheme is proposed to enlarge the distance between the activated transmit antennas, thus reducing the undesirable effects of the correlated fading channels. In [88], a diagonal matrix is designed based on the minimum asymptotic average BER under the constraint of limited power resource. In [89] and [90], the idea of trellis-coded modulation (TCM) is introduced to the choice of activated transmit antennas. By sending the spatial information bits into a convolutional encoder designed based on the TCM principle, the encoded bits for antenna activation can guarantee that the spatial distance between the transmit antennas is maximized. Therefore, the detection performance of the APM bits in correlated fading channel increases a lot. On the other hand, the performance of the index bits can be improved as well because of the encoding gain.

Precoding scheme can also be used in the received SM (RSM) applications where the indices of receive antennas are utilized to convey spatial information. Compared with SM or GSM, RSM can take advantage of beamforming gain since all transmit antennas are activated in transmission, and the precoding module is implemented at the transmitter to map the receive antenna indices on the transmit antennas. Furthermore, as the receiver does not need any interference cancellation when the zero-forcing (ZF) or minimum mean square error (MMSE) precoding schemes are considered, the complexity of the receiver can be reduced significantly. Therefore, RSM is highly desirable in the downlink MIMO transmission scenarios.

Differential SM (DSM) is another SM-related technology where the spatial information is conveyed via the activation of the space-time dispersion matrix. DSM technology dispenses with the channel state information (CSI) at the transceiver by exploiting the differential encoding of SM symbols. Sugiura *et al.* [68] propose a DSM architecture in STSK system where the Cayley unitary transform is exploited to assist the transmission of index information. Inspired by the differential encoding

idea, Naresh *et al.* [91] put forward the concept of differential MBM (DMBM) to avoid the requirement of CSI, thus reducing the complexity of receiver to a large scale.

Multiple-mode SIM-OFDM (MM-OFDM) is the extension of DM-OFDM where the constellation modes are enlarged to improve the transmission rate [92]. In MM-OFDM systems, each OFDM subblock consists of P subcarriers, which are split into n_{MM} subsets, and each subset transmits APM symbols belonging to a constellation that is distinguishable to the other $n_{\text{MM}} - 1$ constellations. Therefore, the superior spectrum efficiency is obtained compared to its dual mode counterpart, and is attractive to high-rate communication systems in 6G.

Quadrature IM (QIM) technology improves the throughput by sending both in-phase (I component) and quadrature (Q component) of an APM symbol via independent resource entities according to the index information [93]–[96]. In QIM systems, the source bit sequence is divided into three parts, one for APM symbols, and the other two for the activation of resource entities. However, the two parts of activated resources are used to transmit I/Q components of APM symbols separately. Althunibat *et al.* [97] make a deep analysis on the performance of QIM, and Nahhal *et al.* [98] study the complexity of QIM detectors in detail.

Schamasundar *et al.* [99] propose a scheme by combining the TD-IM and MBM, namely, time-indexed MBM. Such hybrid IM technique can increase the data rate considerably at the cost of detect complexity. Ertugrul *et al.* [100] give a novel SM sparse code multiple access (SM-SCMA) scheme operating in uplink transmission, which is used for organizing the accessing of multiple users. SM-SCMA is an example of non-orthogonal multiple access aided SM (NOMA-SM), which is remarkable in reducing the inter-user interference in 6G multi-user communications [101]. IM-aided systems can also be designed with bit-interleaved coded modulation (BICM) where soft information between the channel decoder and index pattern can be exchanged iteratively to obtain near-capacity performance [102]. In [103], a reduced complexity detector is presented by introducing the compressing theory into the IM-aided system, where the sparsity of the activated resource entities is exploited to detect the information.

Challenges of IM Techniques. Although IM technology has the advantage of high data rate and low energy consumption, it still meets some challenges as follows :

- For IM system, the non-activated resource entities are kept empty in transmission, and therefore the utilization efficiency is unsatisfactory.
- The complexity of detection algorithm is very large.
- Since the APM symbols are conveyed only through the selected resources, once the detection of the index is incorrect, the demodulation is almost destructive in the decoupled detection algorithm.
- In MBM system, the number of mirrors is large to achieve high data rate, therefore, huge training sequence should be required for acquiring the channel states, which consumes a lot of resource in transmission.

IV. ARTIFICIAL INTELLIGENCE

TABLE III
TRANSMISSION RATE FOR EXISTING IM SCHEMES.

Scheme	Spectral Efficiency (bpcu)
SM	$\lceil \log_2 N_T \rceil + \log_2 M$
GSM	$\left\lceil \log_2 \begin{pmatrix} N_T \\ K \end{pmatrix} \right\rceil + K \log_2 M$
SIM-OFDM	$G (\lceil \log_2 P \rceil + \log_2 M) / (L + L_{CP})$
GSIM-OFDM	$\frac{G}{L + L_{CP}} \left(\left\lceil \log_2 \begin{pmatrix} P \\ K \end{pmatrix} \right\rceil + K \log_2 M \right)$
DM-OFDM	$\frac{G}{L + L_{CP}} \left(\left\lceil \log_2 \begin{pmatrix} P \\ K \end{pmatrix} \right\rceil + K \log_2 M_A + (P - K) \log_2 M_B \right)$
TD-IM	$(\lceil \log_2 N_{ns} \rceil + \log_2 M) / N_{ns}$
GTD-IM	$\left(\left\lceil \log_2 \begin{pmatrix} N_{ns} \\ K \end{pmatrix} \right\rceil + K \log_2 M \right) / N_{ns}$
STSK	$(\lceil \log_2 L \rceil + \log_2 M) / N_{ns}$
GSTSK	$\left(\left\lceil \log_2 \begin{pmatrix} L \\ K \end{pmatrix} \right\rceil + K \log_2 M \right) / N_{ns}$
MBM	$N_T \log_2 M + N_T m_r$

Artificial Intelligence (AI) provides intelligence for wireless networks by simulating some human thought processes and intelligent behaviors. In this section, we will present some popular AI technologies, including supervised learning, unsupervised learning, model-driven deep learning, deep reinforcement learning, federated learning, and explainable artificial intelligence and their corresponding applications. Additionally, by leveraging AI technologies, 6G enables various applications in communications such as network planning, network optimization, network operation and maintenance, and autonomous vehicles which are illustrated in Fig. 8 [4, 10,44,104]–[111]. In particular, AI, residing in new local “clouds” and “fog” environments, helps to create many novel applications using sensors that can be embedded into every corner of our life [12]. Table IV lists applications and their corresponding deep learning methods and tools in physical layer, MAC layer, and network layer.

Deep learning, which is considered as the vital ingredient of AI technologies, has been widely used in the wireless networks [112]. It will play an essential role in various areas, including semantic communications, holistic management of communication, computation, caching, and control resources areas, etc., which may push the paradigm-shift of 6G.

Supervised Learning. The supervised Learning trains the machine model using labelled training data [4]. There are some well developed algorithms that can be used in 6G, such as support vector machines, linear regression, logistic regression, linear discriminant analysis, naive Bayes, k-nearest neighbors

and decision tree, etc. Supervised learning techniques can be used in both physical layer and network layer. In physical layer, we can utilize supervised learning for channel states estimation, channel decoding, etc. Supervised learning techniques can be deployed for caching, traffic classification, and delay mitigation and so on in the network layer.

Unsupervised Learning. Unsupervised learning is leveraged to find undefined patterns in the dataset without using labels. Commonly used unsupervised learning techniques include clustering, anomaly detection, autoencoders, deep belief nets, generative adversarial networks, and the expectation–maximization algorithm. In the physical layer, unsupervised learning techniques are applicable to optimal modulation, channel-aware feature-extraction, etc. In addition, unsupervised learning technologies can be used for routing, traffic control, and parameter prediction, etc., in network layer.

Model-Driven Deep Learning. The model-driven approach is to train an artificial neural network (ANN) with prior information based on professional knowledge [107,108,146]. The model-driven approach is more suitable for most communication devices than the pure data-driven deep learning approach, because it does not require tremendous computing resources and considerable time to train what the data-driven method needs [146]. The approach to apply model-driven deep learning proposed by Zappone *et al.* [146] includes two steps: first, we can use theoretical models derived from wireless communication problems as prior expert information. Secondly, we can subsequently tune ANN with small sets of

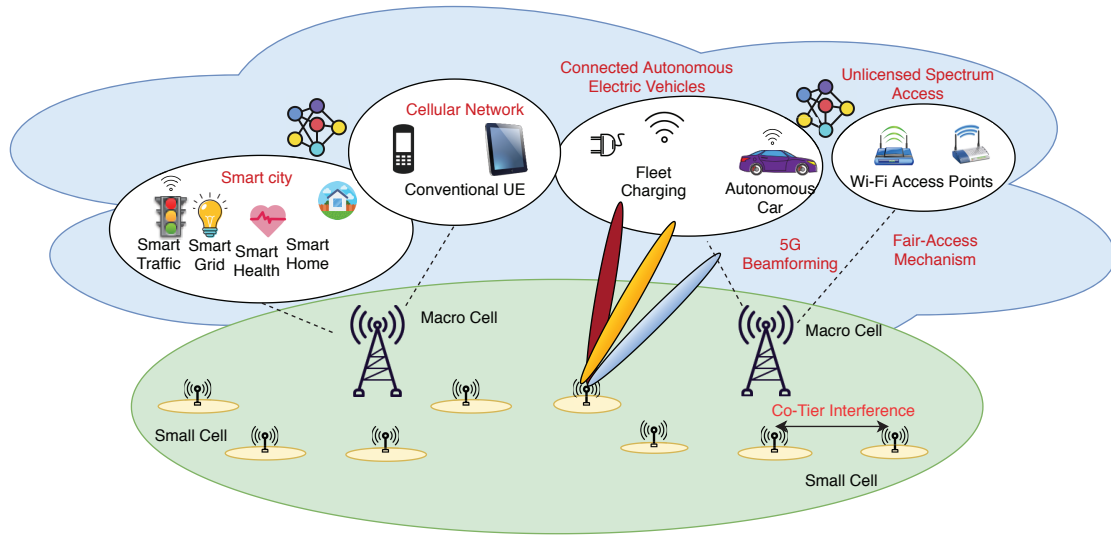

Fig. 8. An AI-Enabled 6G wireless network and related applications.

TABLE IV
MACHINE LEARNING TECHNIQUES OVERVIEW.

ML Types	Description	ML Structures	References
Supervised Learning	Supervised learning is the machine learning task of learning a function that maps an input to an output based on example input-output pairs.	Support vector machine (SVM), K-nearest neighbors (KNN), Multilayer Perceptron (MLP), Bayesian Learning (BL), Deep Neural Network (DNN), Long Short Term Memory (LSTM), Linear regression (LR), Support Vector Regression (SVR), Gaussian Process (GP), Regression, Self-supervised learning	[113], [4], [114], [20], [115], [116], [117], [118], [119], [106], [120], [121]
Unsupervised Learning	Unsupervised learning is a type of machine learning that looks for previously undetected patterns in a data set with no pre-existing labels and with a minimum of human supervision.	K-means, EM, Clustering, PCA, Generative Adversarial Network (GAN)	[4], [20], [113], [115], [122], [21], [123], [124], [59]
Reinforcement Learning	Reinforcement learning is the training of machine learning models to make a sequence of decisions.	Q-learning, Deep Q-learning, Advantage Actor Critic (A2C), Asynchronous Actor-Critic Agents (A3C), Dueling DQN, Double DQN, Proximal Policy Optimization (PPO)	[125], [126], [127], [128], [129], [130], [131], [132], [133], [134], [135]
Federated Learning	Federated learning is a privacy-preserving machine learning technique, which allows users to hold data locally and send trained models to the central server for obtaining the global model.	Decentralized Learning	[114], [136], [137], [138], [139], [140], [141], [142], [143], [144], [145]

live data even though initial theoretical models are inaccurate.

Deep Reinforcement Learning. Deep reinforcement learn-

ing (DRL) leverages Markov decision models to select the next “action” based on the state transition models [112]. DRL technique is considered as one of the promising solutions to maximize some notion of cumulative reward by sequential decision-making [4]. It is an approach to solve resource allocation problems in 6G [106,111]. As 6G wireless networks serve a wider variety of users in the future, the radio-resource will become extremely scarce. Hence, efficient radio-resource allocation is urgent and challenging [106].

Federated Learning. Federated Learning (FL) aims to train a machine learning model with training data remaining distributed at clients in order to protect data owners’ privacy [147]. As 6G heads towards a distributed architecture, FL technologies can contribute to enabling the shift of AI moving from a centralized cloud-based model to the decentralized devices based [11,105,148]. In addition, since the edge computing and edge devices are gaining popularity, AI computing tasks can be distributed from a central node to multiple decentralized edge nodes. Thus, FL is one of the essential machine learning methods to enable the deployment of accurately generalized models across multiple devices [149]. The idea of FL is illustrated in Fig. 9, where users’ devices train local models and then send trained local models to the base station for aggregation. Since users’ data are still maintained in the devices, the privacy of their data can be well preserved.

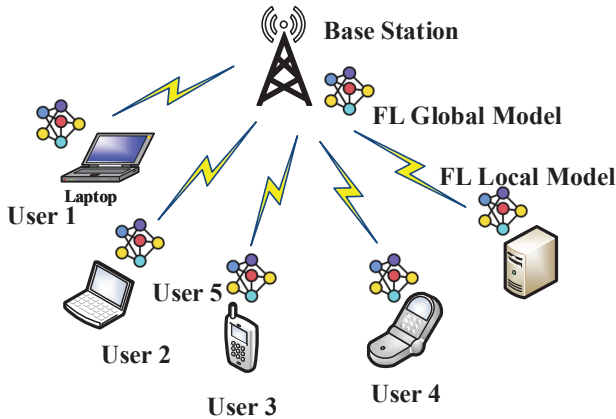

Fig. 9. Federated Learning.

Explainable Artificial Intelligence. Since there will be a large scale of applications such as autonomous driving and remote surgery in 6G era, it is necessary to make AI explainable for building trust between humans and machines. Currently, most AI approaches in PHY and MAC layers of 5G wireless networks are inexplicable [150]. AI applications such as autonomous driving and remote surgery are considered to be widely used in 6G, which requires explainability to enable trust. AI decisions should be explainable and understood by human experts to be considered as trustworthy. Existing methods, including visualization with case studies, hypothesis testing, and didactic statements, can improve the explainability of deep learning.

V. INTELLIGENT SURFACES

Currently, two types of intelligent surfaces attract researchers’ attention, including large intelligent surface (LIS) and intelligent reflecting surface (IRS) which are shown in Fig. 10. LISs are useful for constructing an intelligent and active environment with integrated electronics and wireless communications [151,152]. Renzo *et al.* [153] believe that IRSs will be utilized in 6G, because they predict that future’s wireless networks will serve as an intelligent platform connecting the physical world and the digital world seamlessly. They foresee that wireless networks will be smart radio environments which have potentials to realize uninterrupted wireless connectivity and use existing radio waves to transmit data without generating new signals. In the following, we will introduce LIS and IRS in detail.

LIS. The concept of deploying antenna arrays as LISs in massive MIMO systems is originally proposed by Hu *et al.* [154]. LISs are electromagnetically active in the physical environment, where each part of an LIS can send and receive electromagnetic fields. Buildings, streets, and walls are expected to be electronically active after decorating with LISs [151]. As Radio Frequency circuits and signal processing units are embedded in the surface, the entire surface of LIS can be used to transmit and receive communication signals. LISs have the following main favorable features [151]: (i) Generate perfect LoS indoor and outdoor propagation environments. (ii) They put little restriction on the spread of antenna elements. Hence, mutual coupling effects and antenna correlations can be easily avoided, such that sub-arrays are large and the channel is well-conditioned for propagation. Thus, LISs can be realized via THz Ultra-Massive MIMO (UM-MIMO). LISs are very useful for applications with low-latency because channel estimation techniques and feedback mechanisms that LISs support are simple.

IRS. The IRS is considered as a promising candidate to improve the signal quality at the receiver by modifying the phase of incident waves [152,154]–[160]. IRSs are made of electromagnetic (EM) material that are electronically controlled with integrated low-cost passive reflecting elements, so that they contribute to forming the smart radio environment [161]. The highly probabilistic wireless channel is tuned into a deterministic space by using the software-controlled propagation of the EM waves in the smart radio environment realized by IRSs. IRSs help to enhance the communication between a source and a destination by reflecting the incident wave [161]–[163]. By adjusting the reflection coefficients at the IRS, IRSs enable the reflected signals being coherently added to the receiver without adding additional noise [163]. Besides, IRSs can modify the signal phase and increase signal power [151]. In particular, by utilizing local tuning, graphene-based plasmonic reconfigurable metasurfaces can obtain some benefits, including beam focusing, beam steering, and control on wave vorticity [164]. Unlike LISs, IRSs use passive array architecture for reflecting purpose [165]. In the following, we list some features of IRSs summarized by Basar *et al.* [161] and Wu *et al.* [165] :

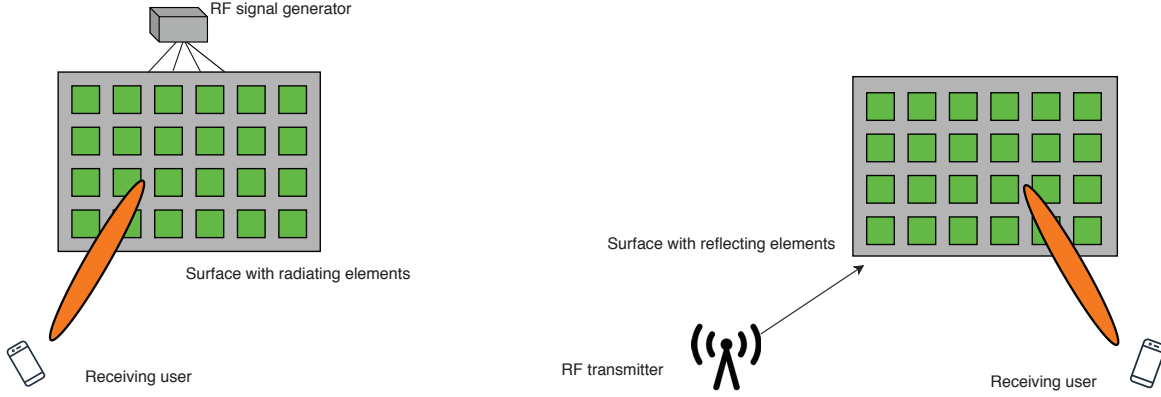

Fig. 10. Left: Large Intelligent Surfaces (an RF signal generator locates at the backside). Right: Intelligent Reflecting Surfaces (an RF signal generator locates at another location).

- They comprise low-cost passive elements which are controlled by the software programming.
- They do not require specific energy source to support during transmission.
- They do not need any backhaul connections to exchange traffics.
- The IRS is a configurable surface, so that points on its surface can shape the wave impinging upon it.
- They are fabricated with low profile, lightweight, and conformal geometry such that they can be easily deployed.
- They work in the FD mode.
- No self-interference.
- The noise level does not increase.

The structure of IRS is depicted in Fig. 11. The base station (BS) equipped with N_T antennas is communicating with one or multiple single-antenna cell-edge user equipment (UE). Since the channel fading of the BS-UE direct link is too large to guarantee the QoS, an IRS of N_I units is utilized to facilitate the communication.

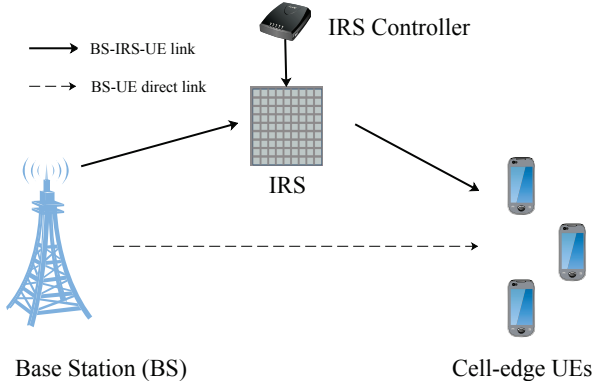

Fig. 11. Structure of IRS system.

Suppose there are (is) N_{UE} UE(s) in the IRS-aided wireless communication systems ($N_{\text{UE}} \geq 1$). The received signal for the n th UE is given by

$$y_{1,n} = (\mathbf{h}_{1,n} \Phi \mathbf{H}_{1,B} + \mathbf{h}_{B,n}^T) \mathbf{x} + w_n, \quad n = 1, 2, \dots, N_{\text{UE}}, \quad (22)$$

where $\mathbf{h}_{1,n} \in \mathbb{C}^{1 \times N_I}$ and $\mathbf{h}_{B,n} \in \mathbb{C}^{1 \times N_T}$ are the channel fading vectors between the IRS and the n th UE and the BS and the n th UE, respectively, $\mathbf{H}_{1,B} \in \mathbb{C}^{N_I \times N_T}$ is the channel fading matrix between the BS and the IRS, w_n is the additive white Gaussian noise at the n th UE, $\mathbf{x} \in \mathbb{C}^{N_T \times 1}$ is the transmitting signal vector of the BS, and $\Phi \in \mathbb{C}^{N_I \times N_I}$ is a diagonal matrix whose diagonal elements are the corresponding reflect coefficients of the IRS, i.e.,

$$\Phi = \text{diag}(\phi_1, \phi_2, \dots, \phi_{N_I}) \quad (23)$$

with $\phi_i (i = 1, \dots, N + I)$ is the reflect coefficient of the IRS's i th element. By defining $\boldsymbol{\varphi} = [\phi_1, \dots, \phi_{N_I}]^T$, the received signal can be rewritten as

$$y_{1,n} = (\boldsymbol{\varphi} \text{diag}(\mathbf{h}_{1,n}) \mathbf{H}_{1,B} + \mathbf{h}_{B,n}^T) \mathbf{x} + w_n, \quad n = 1, 2, \dots, N_{\text{UE}}. \quad (24)$$

Compared with Eq. (22), Eq. (24) is more convenient to be processed.

However, $\mathbf{h}_{B,n}^T$ is often omitted since the distance between the BS and UE is long and the channel fading degrades considerably fast. The reflect coefficient has two parts: phase shift θ_i and amplitude attenuation α_i , i.e.,

$$\phi_i = \alpha_i e^{1j\theta_i} \quad (i = 1, \dots, N_I) \quad (25)$$

with $1j$ is the imaginary unit.

According to whether the models for the phase shift and amplitude attenuation are continuous or not, the IRS can be classified into continuous mode and discrete mode. For the phase shift, ϕ_i can take any value in the range of $[0, 2\pi)$ in the continuous mode, however, ϕ_i can only take a finite number of values in $[0, 2\pi)$ in the discrete mode. Similarly for the amplitude attenuation, when there is no attenuation for the coefficients, $\alpha_i = 1$, and when the amplitude attenuation is in the continuous mode, α_i can take any value in $(0, 1]$ or a finite number of values between 0 and 1 in the discrete mode. However, when the phase shift or the amplitude attenuation are in the discrete mode, the optimization problem of maximizing the capacity or minimizing the transmitting power as discussed later are non-convex. The generally-used method is to solve the problem considering the phase shift and amplitude attenuation in continuous mode, and choose the discrete values that are

close to the solved continuous solutions. The problem with no amplitude attenuation also makes the constraint non-convex, and in such a case the optimization can be done first by neglecting this non-convex constraint and then by normalizing the phase shifts to fulfill the constraint of unit modulus [166]–[168].

1) *IRS-aided Multi-users System*: As illustrated in Fig. 11, suppose the N_{UE} cell-edge UEs are divided into G groups with each group has $N_{\text{UE}}^{(g)}$ UEs ($g = 1, 2, \dots, G$), therefore, parameters $N_{\text{UE}}^{(g)}$ make the equation hold:

$$\sum_{g=1}^G N_{\text{UE}}^{(g)} = N_{\text{UE}}. \quad (26)$$

The transmitting signal vector can be expressed as

$$\mathbf{x} = \sum_{g=1}^G \boldsymbol{\omega}_g x_g, \quad (27)$$

where $\boldsymbol{\omega}_g \in \mathbb{C}^{N_T \times 1}$ and x_g are the beamforming vector and transmitted signal for UEs in group g , respectively. Consequently, the signal-to-interference-plus-noise ratio (SINR) for the n th UE is given by

$$\text{SINR}_n = \frac{\|\boldsymbol{\varphi} \text{diag}(\mathbf{h}_{1,n} \mathbf{H}_{1,B} \boldsymbol{\omega}_g)\|^2}{\sum_{g'=1, \dots, G, g} \|\boldsymbol{\varphi} \text{diag}(\mathbf{h}_{1,n} \mathbf{H}_{1,B} \boldsymbol{\omega}'_{g'})\|^2 + \sigma_n^2} \quad (28)$$

with σ_n^2 denotes the variance of noise at the n th UE, and the channel fading of the direct BS-UE link is neglected since its variance is far smaller compared to that of the BS-IS-UE link.

Thus, the optimization problem can be constructed by minimizing the transmitted signal power, i.e., power control under reliability constraints:

$$\begin{aligned} \text{(A-IRS)} \quad & \min_{\boldsymbol{\omega}_1, \dots, \boldsymbol{\omega}_G, \boldsymbol{\varphi}} \sum_{g=1}^G \|\boldsymbol{\omega}_g\|^2 \\ & \text{subject to} \quad \text{SINR}_n \geq \gamma_n \quad n = 1, \dots, N_{\text{UE}}, \\ & \quad |\phi_i| = 1, \quad i = 1, \dots, N_I, \end{aligned} \quad (29)$$

where $\gamma_n (n = 1, \dots, N_{\text{UE}})$ is the predefined SINR threshold for each UE.

In addition, the problem can also be given by maximizing the minimal SINR among all the UEs for a given maximal transmitting power:

$$\begin{aligned} \text{(B-IRS)} \quad & \max \min_{\boldsymbol{\omega}_1, \dots, \boldsymbol{\omega}_G, \boldsymbol{\varphi}} \text{SINR}_n, \\ & \text{subject to} \quad \sum_{g=1}^G \|\boldsymbol{\omega}_g\|^2 \leq P_{\max}, \\ & \quad |\phi_i| = 1. \end{aligned} \quad (30)$$

In problems (A-IRS) and (B-IRS), the constraints $|\phi_i| = 1, i = 1, \dots, N_I$ are only effective when there exists no amplitude attenuation for IRS. By solving the problem, the joint IRS coefficients and beamforming vector for IRS-aided multi-user system can be obtained. As illustrated in [33, 169, 170], for a given maximum transmitting power, the SINR can be scaled quadratically in the order of the number of IRS elements, thereafter, the received reliability of the system can be improved significantly as N_I increases.

Furthermore, the communication system can be classified into broadcast, multicast and unicast according to whether the group $G = 1, 1 < G < N_{\text{UE}}$ or $G = N_{\text{UE}}$. In broadcast systems all UEs receive the same information from the BS. Therefore, there does not exist any inter-user interference in Eq. (28) and only additive white Gaussian noise has effect on the receiver. In unicast systems, each UE receives its own information independently, thus each UE will be influenced by other UEs. In multicast systems, all the UEs are grouped based on their received signal, and each group has its own information different from others. Broadcast and unicast systems are special cases of multicast systems.

2) *Channel Estimation for IRS-Aided Systems*: In the previous subsection, to obtain the optimal IRS coefficients by solving the optimization problem (A-IRS) or (B-IRS), the knowledge of channel fading matrices should be available.

Nadeem *et al* [177] propose a channel estimation protocol based on the MMSE principle. The protocol first estimates the channel coefficients between BS and UEs by turning off the IRS, and then estimates the BS-IRS-UE link by turning on the IS unit in turns. Finally, MMSE approach is utilized to obtain a comprehensive estimation of all channels. This protocol is complicated and time consuming due to the fact that each IS should be turned on once a time while the others turned off, especially when the number of IRS elements is large. He *et al.* [178] propose a three-state channel estimation algorithm for MIMO systems. The algorithm first obtains the channel matrices of the BS-IRS and IRS-UE links via matrix factorization. Then, by exploiting the IS state matrix, the ambiguity of the solutions to matrix factorization is eliminated. In the final stage, the properties of channel matrices are utilized to recover the missing entries. The proposed estimation algorithm is also time consuming because the IS units should also be turned on in turns to eliminate the ambiguity in the second stage. In [179], Zheng *et al.* propose a novel method to estimate the channel state information for IRS-enhanced OFDM systems. The authors first design a reflection pattern of the IRS for channel estimation by exploiting pilot signals, and then perform a joint channel estimation and reflection optimization based on the strongest signal path resolved in the first stage. This novel method avoids the requirement of large numbers of pilot signals and operation for each IRS units, therefore, reducing the complexity of the receiver for a large scale.

3) *Other IRS Technologies*: Besides the fundamental application as described above, there exist some other IRS-assisted communication systems or IS technologies in the available references. For instance, Yang *et al.* [174] discuss the application of IRS in OFDM systems where multiple paths exist in the wireless communication environment. The authors establish an objective of maximizing the capacity with the maximum transmitting power limited, where the coefficients of IRS and the power allocation for each subcarrier are unknown parameters. By exploiting the idea of alternating optimization, the optimal power allocation and the IS coefficients can be derived. Hu *et al.* [175] investigate the capacity performance with hardware impairments exist in IRSs. The authors also give a conclusion that by splitting the IRS into several subgroups

TABLE V
DEVELOPMENTS OF IRS TECHNOLOGY.

Developments	Key IRS Technologies
IRS-aided multi-user systems [171]–[173]	- Maximization of transmission rate with power constraint - Minimization of transmitting power with received SINR constraint
IRS-aided OFDM systems [174]	Maximization of capacity with power constraint
IRS systems with hardware impairment [175]	Capacity performance is investigated
IRS-aided SM systems [176]	BER performance of IRS-SM/IRS-SSK is investigated
Channel estimation	- MMSE principle [177] - Matrix factorization, ambiguity elimination, matrix completion [178] - Joint optimization of channel estimation and IRS reflection [179]
Phase-dependent amplitude model for IRS schemes	- Lorentzian resonance response $\phi_i = (1j + e^{1j\eta_i})/2$ [180] - Lumped circuit model $\alpha_i = (1 - \alpha_{\min})[(1 + \sin(\theta_i - \eta))/2]^k + \alpha_{\min}$ [181,182]

with each subgroup consists of a number of IRS units, the performance degradation can be mitigated to a certain degree. Basar [176] investigate the bit-error rate (BER) performance of the IRS-aided SM systems. In the manuscript, optimal (exhaustive search) and suboptimal (greedy) detectors for the IRS-assisted SM or SSK schemes are formulated in detail, and their theoretical average bit error probabilities are derived as well, to give a benchmark of the IRS-IM/SSK wireless communication systems.

The above models all consider that the phase and amplitude of IRS units are independent to each other. However, in some cases, the amplitudes of IRS units are relevant to their own phases. Di *et al.* [180] construct a reflecting coefficient model by exploiting the Lorentzian resonance response [183], where the coefficient is expressed as $\phi_i = (1j + e^{1j\eta_i})/2$ with $\eta_i \in [0, 2\pi)$. In addition, Abeywickrama *et al.* consider a phase-dependent amplitude model in [184,185] according to the lumped circuit model [181,182]. The amplitude of coefficient is represented as $\alpha_i = (1 - \alpha_{\min})[(1 + \sin(\theta_i - \eta))/2]^k + \alpha_{\min}$, where constant parameters $\alpha_{\min} \in [0, 1]$, $\eta \geq 0$, and $k \geq 0$ are set depending on the specific circuit implementation. The developments of IRS technology in available references are listed in Table V.

A. Comparisons between IRS and other Technologies

Besides LIS and IRS, some other similar technologies have appeared in recent years. These technologies have the same idea of IS, but differs in materials or functionalities.

- large intelligent metasurface (LIM): LIM uses a special metallic material called meta-atom to form its surface, which is more flexible in manipulating electromagnetic waves [186].
- smart reflect arrays: smart reflect arrays put more emphasis upon the reflection function other than the transmission, reception and waveguiding functions [171]–[173].

- software-defined surface (SDS) / software-defined meta-surface (SDM): SDS/SDM introduces the thought of software-defined radio into smart surfaces and by controlling the smart surface units through programmable fashion [176,187].

As the above mentioned technologies have almost similar functions with LIS or IRS, and in our survey, we put stress on the investigation of these intelligent surfaces' quality of service (QoS) enhancement, therefore, we use the name IRS in our following manuscript for general purpose. Different from existing technologies such as backscatter communication, active relay, and active surface based massive MIMO, the IRS-aided network includes both active components (BS, user terminal) and passive component (IRS). We highlight some differences between IRS and well-known technologies as follows.

mMIMO. IRSs and mMIMO consist of different array architectures (passive versus active) and operating mechanisms (reflecting versus transmitting) [165]. Benefiting from the passive elements, IRSs achieve much more gains compared to massive MIMO while consuming low energy [188].

Amplify-and-Forward (AF) Relay. Relay uses active transmit elements to assist the source-destination communication, but the IRS serves as a passive surface, which reflects the received signal [165,188]. Relays help to reduce the rate of the available link if they are in HD mode. When they operate in FD mode, they are subject to severe self-interference. Active relay usually works in half duplex (HD) mode for reduced self-interference. While IRS can work in FD mode, improving the spectrum efficiency compared to the former. Active relay usually works in the HD mode, which wastes spectrum compare to IRS, which works under FD mode. If AF implements FD mode, it needs costly self-interference cancellation techniques to implement. IRS overcomes AF's outstanding shortcomings.

Backscatter. Backscatter requires the reader to implement

self-interference cancellation at the receiver to decode the radio frequency identification (RFID) tag's message. RFID communicates with the reader by modulating its reflected signal sent from the reader [165]. However, IRS only reflects received signals without modifying information; thus, the receiver can add both the direct-path and reflect-path signals to improve the decoding's signal strength.

B. Holographic Radio

Holography radio is the highest level of interference exploitation and it improves spectrum efficiency and network capacity by controlling the entire physical space and the full loop of the electromagnetic field through spatial spectral holography and spatial wave field synthesis [6,189,190]. Specifically, unwanted signals are treated as noises, and people try to reduce the interference caused by these noises. However, in 6G, the interference is regarded as useful resources for developing holographic communication systems [104]. Interference exploitation is that communication system obtains gains through decomposing interference. According to [191], the multi-user interference can be decomposed into constructive and destructive parts using simple geometric relations. Constructive part is considered as beneficial communication resources, which can be used to improve QoS of 6G communication systems. In recent years, MIMO is gaining its popularity because of its high throughput. Thus, 6G is expected to realize holographic MIMOs (HMIMOS) by combining MIMOS with LIS or IRS. HMIMOS can be categorized as active HMIMOS and passive HMIMOS based on the power consumption, which are supported by LIS and IRS, respectively [189]. To be more specific, active HMIMOS using LIS are equipped with RF circuits and signal processing units, whereas passive HMIMOS only use IRS for reflecting signals.

VI. SIMULTANEOUS WIRELESS INFORMATION AND POWER TRANSFER (SWIPT)

SWIPT is another novel technology promisingly used in 6G where energy harvesting through RF signals can be made to fulfill the requirement of high power efficiency [192]–[197]. In 2008, Varshney *et al.* first propose the concept of SWIPT [194], and subsequently, transceivers are designed to realize receiving the information together with energy simultaneously in practical. Available references mainly focus on the circuit design of power transfer or the communication application of SWIPT. In our survey, we principally lay emphasis on the later, especially on the RF signal resource allocation structures and various SWIPT-based systems in communication.

A. Architecture of SWIPT

The two generally-used kinds of structures for resource allocation are time switching (TS) structure and power splitting (PS) structure. In TS structure, a frame consisting of several time slots are classified into information transfer slots and power transfer slots, and a switcher is used at the receiver

to decide which state is at work [198,199]. In PS structure a power splitting factor is utilized to decide how much signal flows to the decoder circuit or the battery circuit.

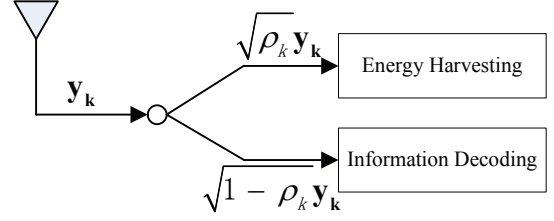

Fig. 12. Architecture of SWIPT system.

The receiver splits the received signal into two streams with power ratio $\rho(t) : 1 - \rho(t)$, where the two parts are used for harvesting energy and decoding the information, respectively. The architecture of SWIPT system is depicted in Fig. 12. Assume the received block consists of N_f time slots, therefore the splitting vector can be defined as $\boldsymbol{\rho} = [\rho_1, \dots, \rho_{N_f}]^T$. For the PS structure, the ratio of the power used for harvesting energy and decoding information can be set as a constant ρ , therefore, the element of the splitting vector is $\rho_k = \rho, (k = 1, \dots, N_f)$. However, for the TS structure, in the first αN_f time slots, the received signal power are used for energy harvesting overall, and vice versa, all the signal power are exploited for information decoding for the remaining $(1 - \alpha)N_f$ time slots. Therefore, the element of the splitting vector for TS structure can be expressed as

$$\rho_k = \begin{cases} 1, & k = 1, \dots, \alpha N_f, \\ 0, & k = \alpha N_f + 1, \dots, N_f. \end{cases} \quad (31)$$

B. Rate-Energy Trade-off

By changing the splitting vector $\boldsymbol{\rho}$, there exists a problem throughout the SWIPT system about how much signal resource should be allocated for harvesting the energy or decoding the information, i.e., trade-off between decoded information rate and energy harvesting (R-E trade-off). Suppose the received signal is expressed as

$$\mathbf{y}_k = \sqrt{\frac{P_s}{N_T}} \mathbf{H}_k \mathbf{x}_k + \mathbf{w}_k, \quad k = \alpha N_f + 1, \dots, N_f, \quad (32)$$

where $\mathbf{y}_k \in \mathbb{C}^{N_R \times 1}$ is the received signal at the k th time slot, $\mathbf{H}_k \in \mathbb{C}^{N_R \times N_T}$ is the channel coefficients, $\mathbf{x}_k \in \mathbb{C}^{N_T \times 1}$ is the transmission vector at time slot k with the mean power of unity, $\mathbf{w}_k \in \mathbb{C}^{N_R \times 1}$ is the channel noise whose element is of mean zero and variance σ_k^2 , and P_s is the power of the transmission vector.

After the splitting operation, the two streams used for energy harvesting and information decoding can be respectively expressed as

$$\mathbf{y}_k^P = \sqrt{\epsilon \rho_k} \sqrt{P_s} \mathbf{H}_k \mathbf{x}_k + \sqrt{\epsilon \rho_k} \mathbf{w}_k \quad (33)$$

and

$$\mathbf{y}_k^I = \sqrt{(1 - \rho_k)} \sqrt{P_s} \mathbf{H}_k \mathbf{x}_k + \sqrt{(1 - \rho_k)} \mathbf{w}_k + \mathbf{w}_c, \quad (34)$$

where ϵ is the energy conversion efficiency and $\mathbf{w}_c \in \mathbb{C}^{N_R \times 1}$ is the down frequency conversion noise with the element of variance σ_c^2 .

According to Eq. (33) and Eq. (34), the average SNR at the k th time slot for the information receiver can be written as

$$\text{SNR}_k = \frac{(1 - \rho_k)P_s}{(1 - \rho_k)\sigma_k^2 + \sigma_c^2}. \quad (35)$$

The R-E trade-off is to find a feasible region where both the decoded information rate and the harvested energy can fulfill the predefined requirements. By denoting the decoded information rate as R and the harvesting energy as E , the feasible region can be referred to as

$$F = \left\{ (R, E) : E \leq \frac{1}{N_f} \sum_{k=1}^{N_f} \rho_k \epsilon P_s, \right. \\ \left. R \leq \frac{1}{N_f} \sum_{k=1}^{N_f} \log_2 \left(1 + \frac{(1 - \rho_k)P_s}{(1 - \rho_k)\sigma_k^2 + \sigma_c^2} \right) \right\}, \quad (36)$$

where Eq. (36) shows the feasible R-E trade-off region for SWIPT system, and the splitting vector can be designed according to the above equation to satisfy both the rate and energy requirements.

C. NOMA-based Relay Systems with SWIPT

Available references also conduct considerable researches on the NOMA-based relay networks with SWIPT. In [200]–[203], they focus on the outage probability, throughput and sum rate performance on NOMA-based networks with SWIPT, and in [204]–[206], authors perform error probability analysis on the NOMA system. Fig. 13 shows the structure of NOMA-based relay downlink system.

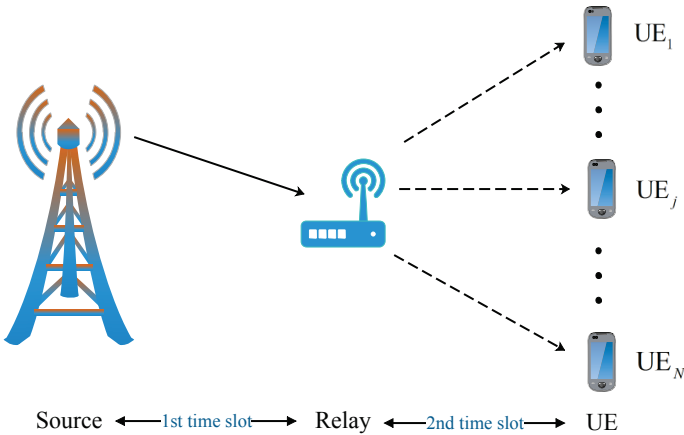

Fig. 13. Structure of NOMA-based relay downlink system.

Assuming single antenna is equipped with the source, relay and N UEs, and no direct link exists between source and UEs due to the severe fading of channel states. The sending signal can be given by

$$x_{\text{NOMA}} = \sum_{j=1}^N \sqrt{\alpha_j} s_j, \quad (37)$$

where $s_j (j = 1, \dots, N)$ is the modulated APM symbol with $\mathbb{E} \|s_j\|^2 = 1$, $\alpha_j (j = 1, \dots, N)$ is the assigned power coefficient with $\alpha_1 > \alpha_2 > \dots > \alpha_N$ and $\alpha_1 + \dots + \alpha_N = 1$.

The received signal at the relay can be expressed as

$$y_{\text{R-NOMA}} = h_{sr} \sqrt{P_s d_{sr}^{-f}} x_{\text{NOMA}} + w_{sr}, \quad (38)$$

where h_{sr} is the channel fading modeled as complex Gaussian random variable with zero mean and unit variance, P_s is the transmitting power, d_{sr} is the distance between source and relay, $f > 2$ denotes the path loss exponent, w_{sr} is the additive white Gaussian noise of variance σ_{sr}^2 . Suppose the power splitting factor is ρ and the energy conversion efficiency is ϵ , the harvested power at relay is referred to as

$$P_r = \epsilon \rho P_s d_{sr}^{-f}, \quad (39)$$

and the signal for information decoding is given by

$$y_I = \sqrt{(1 - \rho)} y_R + w_r \\ = \sqrt{(1 - \rho) P_s d_{sr}^{-f}} h_{sr} x_{\text{NOMA}} + \sqrt{(1 - \rho)} w_{sr} + w_r, \quad (40)$$

where w_r is the down frequency conversion noise at relay.

For AF mode, P_r is the transmitting power at relay and the amplifying gain can be given as

$$G = \sqrt{\frac{\epsilon \rho P_s d_{sr}^{-f}}{(1 - \rho) P_s d_{sr}^{-f} + (1 - \rho) \sigma_{sr}^2 + \sigma_r^2}}. \quad (41)$$

Therefore, the received signal at the j th UE can be written as

$$y_j = \sqrt{(1 - \rho) P_s d_{sr}^{-f} d_j^{-f}} G h_j h_{sr} x_{\text{NOMA}} + w_j, \quad (42) \\ j = 1, \dots, N,$$

where d_j is the distance between relay and the j th UE, and w_j is the total noise at the j th UE which can be expressed as

$$w_j = \sqrt{(1 - \rho) d_j^{-f}} G h_j w_{sr} + \sqrt{d_j^{-f}} G h_j w_r + w_{rj}, \quad (43) \\ j = 1, \dots, N$$

with w_{rj} is the channel noise of the j th UE of variance σ_{rj}^2 . Therefore, the signal-to-noise ratio (SNR) of the j th UE can be expressed as

$$\text{SNR}_j = \frac{(1 - \rho) P_s d_{sr}^{-f} d_j^{-f} G^2}{(1 - \rho) d_j^{-f} G^2 \sigma_{sr}^2 + d_j^{-f} G^2 \sigma_r^2 + \sigma_{rj}^2}, \quad (44) \\ j = 1, \dots, N.$$

According to Eq. (37)-(44), an objective can be set by maximizing the system capacity under the constraint of transmitting power, i.e.,

$$\text{(A-SWIPT)} \quad \max_{\rho} \sum_{j=1}^N \log_2(1 + \text{SNR}_j) \quad (45) \\ \text{subject to } P_s \leq P_{\text{max}},$$

where P_{max} is the available maximum transmitting power. By solving problem (A-SWIPT), the optimum power splitting factor can be obtained for NOMA relay system with SWIPT.

At the UE side, successive interference cancellation (SIC) algorithm can be used to recover each UE's source information, and the symbol error rate (SER) or BER performance can

also be conducted according to the pairwise error probability (PEP) [204]–[206].

By combining SM and SWIPT together, the data rate can be enhanced for a large scale under energy constraint systems. Suppose the number of antennas at the source and destination are respectively N_T and N_R , which are the same as previously mentioned, and the relay is equipped with N_A antennas. The structure of SM-SWIPT system is shown in Fig. 14.

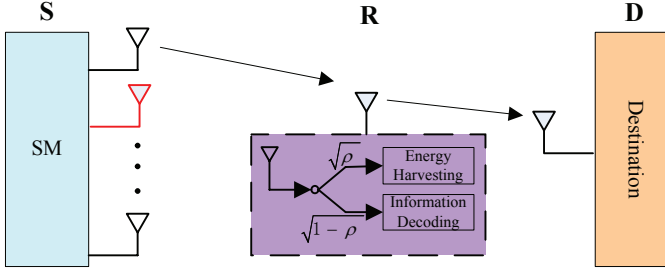

Fig. 14. Structure of SM-based relay downlink system with SWIPT.

In Fig. 14, the source exploits SM technology to generate the transmitting signal, and the received signal at the relay can be given by

$$\mathbf{y}_{R-SM} = \sqrt{P_s d_{sr}^{-f}} \mathbf{H}_{sr} \mathbf{x}_{SM} + \mathbf{w}_{sr}, \quad (46)$$

where $\mathbf{y}_{R-SM} \in \mathbb{C}^{N_A \times 1}$ is the received signal vector at relay side, $\mathbf{H}_{sr} \in \mathbb{C}^{N_A \times N_T}$ is the channel fading matrix between the source and relay, with the element is complex Gaussian random variable, $\mathbf{w}_{sr} \in \mathbb{C}^{N_A \times 1}$ is the additive Gaussian noise at relay, and the parameters P_s , f , d_{sr} , and \mathbf{x}_{SM} have the same meaning as aforementioned.

Accordingly, the expression of the harvested energy has the same expression with Eq. (39), while the signal for information decoding resembles Eq. (40) except that the scalars are replaced by the corresponding vectors or matrices, i.e.,

$$\mathbf{y}_I = \sqrt{(1-\rho)P_s d_{sr}^{-f}} \mathbf{H}_{sr} \mathbf{x}_{SM} + \sqrt{(1-\rho)} \mathbf{w}_{sr} + \mathbf{w}_r, \quad (47)$$

with $\mathbf{w}_r \in \mathbb{C}^{N_A \times 1}$ is the down frequency conversion noise vector at relay.

Also, suppose that AF protocol is used and the received signal at destination can be given by

$$\mathbf{Y}_{D-SM} = \sqrt{(1-\rho)P_s d_{sr}^{-f} d_{rd}^{-f}} \mathbf{G} \mathbf{H}_{rd} \mathbf{H}_{sr} \mathbf{x}_{SM} + \mathbf{w}_d, \quad (48)$$

where $\mathbf{H}_{rd} \in \mathbb{C}^{N_R \times N_A}$ denotes the channel fading matrix between relay and destination, and $\mathbf{w}_d \in \mathbb{C}^{N_R \times 1}$ is the total noise vector of the destination side. Performing the same analysis with NOMA-based relay system, the SNR at destination is written as

$$\text{SNR} = \frac{(1-\rho)P_s d_{sr}^{-f} d_{rd}^{-f} G^2}{(1-\rho)d_{rd}^{-f} G^2 \sigma_{sr}^2 + d_j^{-f} G^2 \sigma_r^2 + \sigma_{rd}^2}, \quad (49)$$

where parameters σ_{sr}^2 and σ_r^2 are the variances of channel noise between source and relay and frequency down conversion noise at relay as aforementioned, while σ_{rd}^2 is the variance

of channel noise between relay and destination. Therefore, the optimization problem can be expressed as

$$\begin{aligned} \text{(B-SWIPT)} \quad & \max_{\rho} \quad \log_2(1 + \text{SNR}) \\ & \text{subject to} \quad P_s \leq P_{\max}. \end{aligned} \quad (50)$$

By solving problem (B-SWIPT), the optimal splitting factor can be obtained and the corresponding BER performance can also be analyzed by computing the PEP of SM system [207, 208].

D. Challenges in SWIPT

The above two SWIPT-based systems exemplify the general usage of SWIPT technology in wireless communication networks. It can degrade the power consumption and takes advantage at scenarios where it is difficult to charge the battery such as volcano and marine areas. However, there still exist some challenges of SWIPT technology:

- Existing studies mainly focus on low-power relays and sensors due to the fact that the level of the harvested energy is too low to satisfy the requirements of large wireless devices.
- In 6G, the dense deployment of wireless devices leads to complex electromagnetic interference, which is desirable to power transfer while adverse to information decoding.
- Intense RF radiation has adverse impact on human health. However, to achieve high QoS of SWIPT-based system, denser sensors or relays should be deployed for energy harvesting, which causes more intense RF exposure.

Therefore, the future direction of SWIPT technology should be put upon higher efficiency of energy conversion, anti-interference algorithms in information decoding or low electromagnetic disturbance to others, and investigation of SWIPT-based networks' effects on human health.

VII. SPACE-AIR-GROUND-SEA INTEGRATED NETWORK

In the 5G network, users only can access to a single wireless communication system, for example, the terrestrial wireless communication system, which is experiencing an explosive growth in both the number of users and services available. To overcome 5G's bottleneck, 6G integrates satellite communication network, UAV communication network, terrestrial communication network, and maritime communication network and builds a space-air-ground-sea integrated network (SAGSIN) to support the global coverage and ubiquitous connection as shown in Fig. 15. These networks may work independently or collaboratively. In previous communication generations, satellite-air-ground integrated network (SAGIN) has been hotly discussed by the academic. For example, SAGIN is the foundation of applications like IoT, big data, and cloud computing as required in 6G. Especially in harsh areas such as ocean and mountains, (SAGIN outperforms the traditional single network in a large scale [209]. Radhakrishnan *et al.* [210] survey the inter-satellite communication from viewpoints of physical layer and network layer. Besides,

Niephaus *et al.* [211] analyze the QoS provisioning in converged satellite and terrestrial networks. They emphasize the technical challenges related to the convergence of satellite and terrestrial networks in detail where the satellite networks act as an complement to the existing terrestrial infrastructures. Hamdi *et al.* [212] carry out a research on a satellite-based hybrid sensor network in the perspective of detection and tracking in mobile scenario. However, all the above references related consider only two networks, either space-ground or air-ground integrated networks, whereas maritime communication will be integrated into communication network to achieve the global coverage.

Different from the space-air-ground integrated network in 5G, SAGSIN also provides coverage for the underwater and deep-sea communications. However, SAGSIN is still facing many challenges as listed in Table VI. In the following, we introduce each component of the SAGSIN in detail.

A. Satellite Communication Network

5G communication network focuses on terrestrial coverage, which leaves some areas uncovered. Satellite communication in 6G is envisioned to integrate with terrestrial communication to provide full coverage and high throughput for the areas where terrestrial wireless communication cannot reach such as rural areas.

Satellite communication can be categorized into Geosynchronous Earth Orbit (GEO) and non-GEO based on the satellites' altitude. Chini *et al.* [213] conclude that a GEO satellite is at an altitude of about 35,800 km. GEO satellite communication uses high frequencies, which aggravates the path loss. Non-GEO satellites have Low Earth Orbit (LEO) and Medium Earth Orbit (MEO). LEO is at an altitude of 500 to 2000 km and MEO one is at an altitude of 8,000 to 12,000 km. Non-GEO satellites have lower end-to-end delay compared to GEO satellites. Different orbits decide that satellites are suitable for different scenarios. GEO is stationary to the Earth, while LEO is moving with the Earth. Therefore, GEO can provide to a designated region with continuous service. However, due to the long distance, it suffers relatively high signal delay. Compared with GEO, LEO has a smaller delay because the orbit is much lower than GEO, which is more convenient to be utilized to communicate with ground terminals, such as GPS communication and satellite phones.

You *et al.* [26] propose some technical challenges faced by the satellite communication as follows :

1. It is important for the design of the physical layer transmission of satellite communication networks to have accurate modeling of the satellite channels.
2. The application of massive MIMO in satellite communication networks is challenging.
3. Since typical multi-satellite network architectures include cooperative satellite transmission by sharing some orbit windows, different clusters, etc., resource allocation is one challenge of satellite communication networks.
4. The physical layer transmission and media access control (MAC) protocols takes an essential part in the challenges of the integration of satellite and ground communication networks.

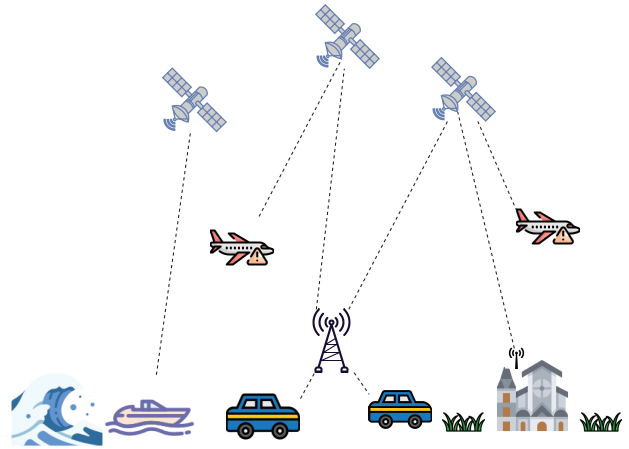

Fig. 15. Space-Air-Ground-Sea Integrated Network.

5. Satellite communication faces challenges in sharing the orbit and spectrum resources among countries [214].

B. UAV Communication Network

A unmanned aerial vehicle (UAV) is an unmanned aircraft, which means it works automatically. A UAV can be viewed as a node. Different UAVs construct a UAV network. Since the UAV communication network is distributed and federated learning is an emerging distributed learning framework, some work combines federated learning with UAV communication networks [215,216]. In [215], Lim *et al.* propose a collaborative learning scheme based on federated learning and involve UAVs for applications in the IoV paradigm. In [216], Zeng *et al.* apply federated learning algorithms to a UAV swarm and also present a joint power allocation and scheduling design, which improves the convergence rate of federated learning.

C. Maritime Communication Network

It is envisioned that deep sea communication will be supported by the robust underwater link in 6G [217]. That is, the underwater links will support the communication among ships, submarines and sensors. In a maritime communication network, it not only has ships but also involves the ashore stations and satellites. There are self-organized ad hoc networks which are consisted of vessels. The function of this network is to accelerate the communication between mobile stations and aid navigation and switch the route [217]. Maritime communication also has several challenges to be overcome. Xia *et al.* [218] conclude eight existing challenges. They are ubiquitous connectivity & service continuity, traffic non-uniformity, service-centricity, device heterogeneity, simplicity & reliability, capacity & scalability, interoperability, and radio spectrum internationality.

VIII. OTHER POTENTIAL TECHNOLOGIES

In this section, we would like to introduce other potential technologies, including device-to-device communication, full-duplex, cell-free massive MIMO, blockchain-based network, terahertz communication, and visible light communication in detail.

TABLE VI
A SUMMARY OF CHALLENGES IN SAGSIN [217]–[219].

Networks	Challenges
Satellite Communication Network	<ul style="list-style-type: none"> - The design of the physical layer transmission to have accurate modelling of the satellite channels; - The application of massive MIMO; - Resource allocation in cooperative satellite transmission; - The physical layer transmission and media access control (MAC) protocols;
UAV Communication Network	<ul style="list-style-type: none"> - UAV deployment is too flexible to reach efficient result; - How to keep users' sessions if the UAV is out of service; - Designing low power consumption is tricky; - Deficiencies like node mobility, network partitioning, intermittent links are remained to be ameliorated; - Optimization of throughput, delay, etc.
Maritime Communication Network	<ul style="list-style-type: none"> - The services over the sea are limited so that ubiquitous connectivity and service continuity are not realized. - The distribution of maritime traffic is sparse on high seas. However, it is more dense close to the shore. - The maritime communication system should adapt to various applications. - The maritime communication network should be able to support different types of devices. - Maritime communication network should be deployed with low costs and high security. - The maritime communication system should be extendible for the growing capacity. - Offer services for various information systems. - Standards and regulations of international frequency band are not addressed.

A. Device-to-Device Communication

As the Internet of Everything (IoE) will be introduced in 6G, the booming increase of the number of edge devices imposes unpredictable pressure to the communication between centralized servers and edge devices. Device-to-Device (D2D) communication enables devices to communicate with each other directly without going through infrastructures like base stations or access points, which guarantees ultra-low latency, speeds up transmission, improves communication quality, and offloads traffic from conventional cellular network in end-to-end communication [45,46]. Thus, D2D communication will gain much more attention in increasing data transmission speed, decreasing end-to-end latency, and reducing the cost of the communication [220].

Specifically, D2D communication can operate in both licensed band and unlicensed band (i.e., Bluetooth and Wi-Fi). Because of the decentralized features that D2D possesses, D2D obtains its advantage in areas, such as mobile edge computing, IoT, and IoE, etc., which also share decentralized features. With the aid of D2D communication, the way of coordination between the centralized server and user's devices has been significantly changed. Users who are close to each other exchange data without forwarding through the BS nearby [221].

Hence, D2D communication can reduce energy consumption, and upgrade users' quality of service (QoS) demands.

D2D is encountering challenges including severe interference, complex resource management, a vast amount of signaling, prohibitively high cost and energy consumption. To facilitate the D2D communication, more advanced and state-of-the-art technologies such as AI and IRS can be utilized [220]. To be more specific, D2D communication will become AI-Driven and intelligent in 6G. One application is to leverage AI to manage resource intelligently. AI-driven D2D communication will enable three kinds of applications, including intelligent D2D-enhanced mobile edge computing, D2D-enabled intelligent network slicing, and NOMA-based D2D cognitive networking. Network slicing (NS) helps to manage and share resources in 5G network. A large number of D2D clusters can extend the flexibility of the network, which enables to provide service according to users' need. In 6G, the large number of D2D clusters can contribute to providing both physical and/or virtual resources, which are critical to build NS. AI will be employed to support manage D2D clusters. The process of distributing resources will be intelligent and automatic, which means that AI will monitor the underlying resource and network slices so as to achieve resource mapping intelligently. Combined with NOMA, D2D will support

cognitive network. Delta-orthogonal multiple access (D-OMA) technique is proposed to obtain the large scale concurrent access. D-OMA which serves as the new multiple access scheme for 6G is leveraged to tackle problems in terminal devices, including the high complexity and increased energy consumption at terminal devices.

B. Full-Duplex

Duplex represents the ability of communication supported by two systems, including transmission and reception [222]. Based on the capability of systems' data flow, the transmission and reception can be simultaneous or asynchronous, which are called full-duplex (FD) and half-duplex (HD), respectively. To be more specific, if systems are in FD mode, they can transmit and receive simultaneously; otherwise, they choose to transmit or receive in different time slots. That means that the system using HD has to spend half of time transmitting and the other half of time receiving, which greatly reduces the throughput and efficiency compared with leveraging FD. Fig. 16 and Fig. 17 illustrate differences between full-duplex and half-duplex.



Fig. 16. Full-Duplex.

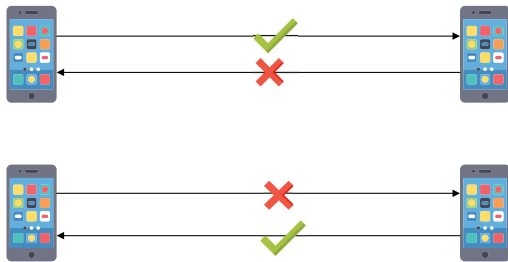

Fig. 17. Half-Duplex.

In the 4G/5G wireless systems, transmission and reception cannot be done at the same frequency or a same time interval, because HD does not support performing the transmission and reception at the same time. Currently, 5G's spectrum is limited to the time division duplex (TDD) or frequency division duplex (FDD), and most of spectral resources are TDD. TDD and FDD are orthogonal transmission which may decrease the efficiency of the utilization of spectrum. FD technique has been enabled by 5G, but it has not been adopted by 3GPP yet.

FD will be utilized completely in 6G wireless systems. FD technologies have the possibility to double current efficiency

in sharing spectrum and increasing the throughput of the networks and communication systems. Both FD and its related techniques such as in-band full-duplex (IBFD) technologies improve the efficiency of communication by allowing devices to transmit and receive a signal in the same frequency band [62]. Compared with HD, FD technology leverages self-interference cancellation technology to increase the utility of spectral resources, improve the throughput, and reduce the transmission delay between transceiver and receiver links. The difference between TDD and FDD will be eliminated, and the true FD mode based on the communication requirements. The arrival of data packets follows Poisson distribution, so that the utility of resources fluctuates dynamically.

By using FD technology, devices can transmit and receive signals at the same time. Yuan *et al.* [223] propose to improve the receiver with self-interference cancellation to realize self-interference cancellation, which uses 20% time-frequency spectrum resources of traditional solution. However, the hard part is to eliminate the self-interference and transmit signal generates over 100dB higher noise than the receiver noise floor. Thus, the new scheduling algorithms and cost saving circuits should be designed for 6G networks. Currently, three types of self-interference cancellation techniques are proposed, which include digital cancellation, analog cancellation, and passive suppression.

Except for self-cancellation techniques, Shen *et al.* [224] and Xu *et al.* [225] propose to utilize intelligent reflecting surface (IRS) introduced in Section V to assist FD to improve the system performance and mitigate the interference. The cost for IRS is much cheaper than relay and it does not consume energy by using its soft-controlled functionalities of electromagnetic (EM) waves. IRS can assist FD application in two ways : (1) IRS acts as a bridge to facilitate FD transmission. Different from RF relays, IRS supports co-time and co-frequency FD transmission scenarios, including line-of-sight (LOS) and non-LOS. (2) Employ IRS to generate reflect/transmission waves of FD signals for specific purposes, including WPT, artificial noise, and cooperative jamming.

By integrating IRS and FD, the energy and cost saving FD-enabled IRS systems are proposed. Besides, the self-interference cancellation is unnecessary because IRS does not require any RF components, and then IRS is free of interference [226]. IRS enables electromagnetic (EM) functions such as anomalous reflection, frequency shifting, absorption, wavefront shaping, nonreciprocity, and focusing, etc. These functionalities can contribute to FD-enabled wireless transmission as follows :

- Anomalous Reflection.
- Frequency Shifting.
- Absorption.
- Wavefront Shaping.
- Nonreciprocity.
- Focusing.

Many applications can leverage FD, including : (1) Application which are in low transmission power scenarios such as device-to-device (D2D) (introduced in Section VIII-A) and vehicle-to-vehicle (V2V) applications. By using FD, V2V communication can be more reliable with low latency. (2)

Sensing-based semi-persistent scheduling (SPS) achieves a relatively better performance. (3) Scenarios equipped transceiver devices with unlimited complexity and cost, such as wireless relay and wireless Backhaul. Scenarios which use spatial freedom and narrow beams.

C. Cell-Free Massive MIMO

Fig. 18 illustrates the conventional cellular system and the Cell-Free Massive multiple-input-multiple-output (CFmMM) systems. Conventional cellular networks use multi-cell MIMO systems, in which an array of co-located antennas serve each cell [227]. Because of the serious path loss, each cell has different performance between cell center and cell edge. According to Shannon theory, both ends of the link should know the propagation channel and dirty paper coding is required. In reality, the size of the wireless system will be limited.

In 6G, CFmMM replaces the traditional APs, equipped with large co-located antenna arrays, with a large number of low-cost access points (APs) which are equipped with few antennas each [62]. The proposed CFmMM systems ensure that user equipment (UEs) can achieve similar performance regardless of position and low-complexity signal processing. To achieve the above goal, CFmMM systems comprise many distributed, low cost, and low power access point antennas whose number is larger than the number of users, so that each user is served by all point antennas simultaneously. Therefore, a CFmMM system is not partitioned into cells any more, and it provides uniform service throughout its coverage area. Besides, cell-free networks are ideally operated in time-division-duplex (TDD) mode, so that uplink pilot signals can be utilized for both uplink and downlink channel estimation.

With the advanced AI technologies that will be widely used in 6G, for example deep learning and federated learning, novel techniques and schemes based on CFmMM are proposed to solve machine learning problems [228,229]. Instead of traditional optimization techniques, Bashar *et al.* [229] have developed a novel deep learning based algorithm which uses a neural network to increase the achievable uplink sum rate of the CFmMM system.

In addition, as the number of mobile phones increases, telecommunications operators start exploring ways to leverage the wireless computation to solve the machine learning problems. To solve the federated learning problems, UEs compute their local updates using their local training data to train local models and send to the central server, while the central processor can be used to aggregate the local models to obtain the global model. Contrary to the traditional deep learning approaches, users can maintain their data locally to support training to prevent from the privacy leakage [228].

D. Blockchain-based network

Blockchain is a chain of blocks which constitute a distributed database. It is designed for cryptocurrencies (e.g. bitcoin) initially. However, nowadays, blockchain can do more

than just in cryptocurrencies but run Turing-complete programs such as smart contracts in a distributed way (e.g. Ethereum) [230]. Blockchain provides a secure and distributed database for storing transaction records, and each node includes the previous block's cryptographic hash, a time stamp, and transaction data [110,231]. Besides, blockchain-like mechanisms are expected to provide distributed authentication, control by leveraging digital actions provided by the smart contracts [44]. Combining with federated learning, blockchain-based AI architectures are shifting AI processing to the edge [232]. Recently, a blockchain radio access network (B-RAN) has been proposed with prototype [233,234]. Thus, blockchain can help to form a secure and decentralized environment in 6G. Blockchain can provide a secure architecture for 6G wireless networks [125].

Blockchain make consensus through miners instead of a central authority as shown in Fig. 19, and it includes a wide range of applications in 6G. Blockchain can help enhance authentication security by the approach of distributed ledger technologies [44]. Besides, blockchain has application in solving the problem of low spectrum utilization and spectrum monopoly when deployed in spectrum sharing system [110]. By integrating wireless networks and blockchain, the central administrator can be eliminated, which improves the network security and reduces costs. As D2D and IoE are gaining popularity in 6G, cooperation among devices is getting more frequent, so that the distributed way of resource management and spectrum control is required. Since blockchain guarantees the transparency, it is easy to track the real-time utilization of the spectrum, which enables to allocate the spectrum dynamically and efficiently. Thus, if 6G wireless network couples with blockchain when building, it will be simple to track the resource management and spectrum sharing. IoT and D2D enable applications such as smart farming, healthcare, machine-to-machine communication, etc.

E. Terahertz Communications

Terahertz (THz) frequency band, which ranges from 0.1 to 10 THz, is the last unexplored span of radio spectrum [188, 235]. THz communications provide ultra-high bandwidth and ultra-low latency communication paradigms [235]. It is envisioned the data rate should be as high as Tbps to satisfy 6G applications' requirements of high throughput and low latency [188]. A novel approach to generate the THz frequency is discovered by Chevalier *et al.* [236]. They build a compact device that can use the nitrous oxide or laughing gas to produce a THz laser whose frequency can be tuned over a wide range at room temperature. Traditionally, the THz gap limits the widespread use of THz. THz transceiver design is regarded as the most critical factor in facilitating THz communications [188].

Recent technology advancements in THz transceivers, such as electronics-based devices and photonics-based devices, overcome the THz gap, and enable some potential use cases in 6G [235]. The electronic technologies such as standard silicon CMOS, silicon-germanium BiCMOS, and III-V semiconductor related technologies (where the roman numerals III and

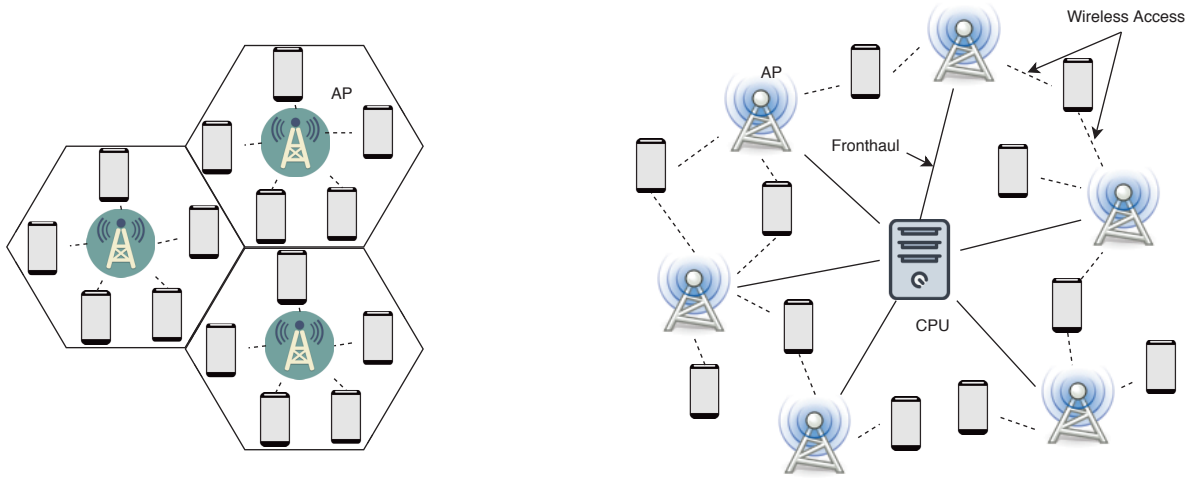

Fig. 18. Traditional Cellular System (left) vs CFmMM System (right).

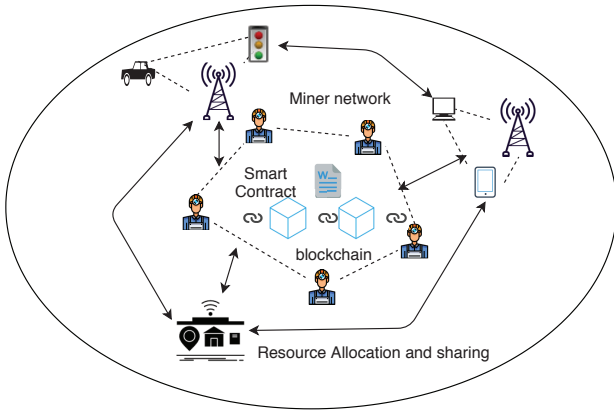

Fig. 19. Blockchain-based network.

V refer to the old numbering of the periodic system groups), have been vastly advanced, such that amplifiers and mixers are able to operate at a frequency close to 1THz [188,237]. The photonic technologies, including optical down-conversion systems based on photomixers or photoconductive antennas, uni-travelling carrier photodiodes (UTC), and quantum cascade lasers (QCLs), have been demonstrated as potential to enable practical THz communication systems [188,237]. In addition, the combination of electronic-based transmitter and photonics-based receiver is feasible. Recent nanomaterials may help to develop novel plasmonic devices for THz communications [237].

Due to the high transmission of RF, signals transmitted through THz frequency band suffer from a high pass loss. According to the Friis' law, the pass loss in free space increases quadratically with the operating frequency [238]. This feature limits the use of THz to short-distance transmission such as indoor communications [239]. Meanwhile, THz band can satisfy the requirement of ultra-high data rate; therefore, ultra-broadband applications such as virtual reality (VR) and wireless personal area networks can also exploit THz band to transmit signals [238]. THz technique can also be used in secure wireless communications. Since THz signals possess a

narrow beam, it's difficult for the eavesdropper to wiretap the information when locating outside the transmitter beam [239].

F. Visible Light Communication

Visible light communication (VLC) is considered as one of the techniques that will be used in 6G, because it operates at the THz frequencies to [240]. Specifically, 6G is moving to higher frequencies because of the spectral congestion in frequencies that 5G use and the increasing requirements for higher data rates. VLC has high data rates, a large frequency spectrum, high-speed transmission, and robustness against interference [241]. Hence, VLC contributes to the development of short-range communications in 6G [242]. For the short-range communication, either data-modulated white laser diodes or light-emitting diodes are used as transmitters, while photodetectors are utilized as receivers. Besides, VLC is considered as a complementary technology for the radio frequency communication because it can utilize an unlicensed spectrum for communication [12].

The laser diode (LD)-phosphor conversion lighting technology can provide better performance in efficiency and brightness, and larger illumination range compared with traditional lighting techniques [188]. Thus, it is considered as the most promising technology for 6G. The speed LD-based VLC system is possible to reach 100Gbps, which meets the requirements of ultra-high data density (uHDD) services in 6G. Besides, the upcoming new light sources based on microLED will overcome the limitation of low speed in short range communication [44]. As massive parallelization of microLED arrays, spatial multiplexing techniques, CMOS driver arrays, and THz communications develop, VLC's data rate is expected to reach Tbps in the short range indoor scenario by the year of 2027 [44,235]. Fig. 20 illustrates the indoor VLC scenario.

VLC is envisioned to be utilized in various applications in 6G. By integrating with SAGSIN, short-range network, and cellular communication, VLC can be used to provide a better coverage [16]. In addition, traditional electromagnetic-wave signals cannot achieve high data transmission speed using

laser beams in the free space and underwater, but VLC has ultra-high bandwidth and high data transmission speed [243]. Therefore, VLC is useful in cases where traditional RF communication is less active, for example, indoor communication, underwater communication, underground communication, and in-cabin internet service [11,244]. Furthermore, VLC is envisioned to be widely used in vehicle-to-vehicle communications, which depend on the head and tail lights of cars for communications [11,188,243]. Besides, VLC serves as a potential solution to build gigabit wireless networks underwater.

However, VLC is still facing many challenges. For example, the bandwidth of the light source restricts the speed of VLC [240], so new materials and mechanisms should be developed to increase the light source's bandwidth. Besides, Si-based detectors used by VLC systems are more sensitive to infrared waves than visible light. Moreover, no application-specific integrated circuits for VLC baseband processing. Furthermore, the data processing for future systems will be much more complex to process.

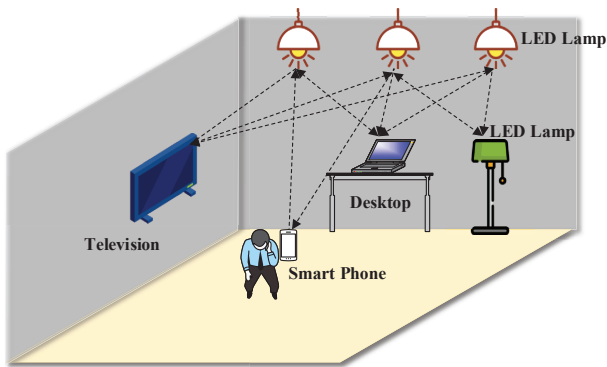

Fig. 20. Visible Light Communication.

G. Network in Box

More and more kinds of technologies will be embedded in 6G, such as autonomous vehicles, factory automation, etc. To satisfy the real-time and reliable features of the network, Network in Box (NIB) technique has attracted much attention from the industrial automation because NIB offers a device that can provide seamless connectivity between different services. On the other hand, NIB covers the wireless environments, including ground, air, and marine well agreed to the vision of IoE in 6G.

IX. SECURITY AND PRIVACY

With the emerge of the 6G technology, there will be more and more edge devices with high mobility conducting wireless communication. The huge amount of wireless communication data, many of which come from mobile applications, may contain sensitive information and involve the privacy of individual users. Because of the broadcast nature of wireless communication, 6G also faces the data leakage problem. In order to

avoid the necessary but complex key sharing in traditional cryptography, some physical layer security methods that can guarantee secure wireless communication are proposed.

Security Risks. Intelligent reflecting surface (IRS) is a kind of metasurfaces which can improve spectrum efficiencies by reconfiguring the reflection angle of signals regardless of incidence angle. It is a promising technology in 6G communication. However, attacks still happen in IRS, and many have been investigated [245]–[247]. The attacks can be classified into two categories: passive attack and active attack.

It is a way to obtain the effective data sent from the original station to the destination station without affecting the normal data communication. By monitoring the effective data, it damages data confidentiality and causes privacy leakage. Passive attack can be subdivided into two distinct classifications: one is to obtain the content of the message directly; the other one is to analyze the data flow. If some approaches, such as encryption, make the attacker unable to obtain the true content of the message from the intercepted parts, the attacker may obtain the message format, determine the location and identity of both sides of the communication, the number of times of communication and the length of the message, which may also be sensitive to both sides of the communication. Since passive attack does not make any modification to the message, it is difficult to detect. One possible solution to avoid the eavesdropping is to maximize the transmit rate.

Active attack is a deliberate act of actively accessing the required data, causing direct impact on legitimate users. Active attack can be divided into three categories : The first one is to intercept the data sent by the original station, interrupting the effective data so that the destination station cannot receive the data sent by the original station. It affects data availability. The second one is to tamper with the data sent from the original station to the destination station, thereby affecting the information received by the destination station. It affects data integrity. The third one is to forge data and send it to the destination station even if the original station does not send data, which affects data authenticity. The main way to deal with active attack is to detect and recover the damage caused by it.

Security Technology. In 6G, when it comes to physical layer security, two basic requirements need to be satisfied: confidentiality and authentication. Confidentiality means that eavesdroppers have no access to the effective data. Authentication makes sure that attackers cannot forge data and send to the destination station. Although traditional cryptographic technologies such as public key cryptography can enforce security, they are all implemented in the upper layer. Wyner shows that secure communication can be achieved in physical layer just by technologies adopted in noise and interference [248], which becomes the foundation of research on security of wireless communication theory. Csiszár and Köner [249] generalize Wyner's result by adopting a non-degraded discrete memoryless broadcast channel. Since then, more and more researchers focus on this field and propose a large number of approaches. Existing methods can be categorized as channel approaches, power allocation approaches and signal processing approaches.

Channel Approaches. In recent years, many researchers

focus on the fundamental issues of secure channel capacity. The main idea of these works is to distinguish quality of signal received by legitimate users and by unauthorized receivers. Wyner had shown that reliable and secure transmission can be achieved in degraded broadcast channels. The perfect secrecy capacity is the gap between the attacker's capacity and legitimate user's capacity for discrete memoryless channels [248]. [250,251] introduce the Gaussian channels on the basis of Wyner's work and generalized the conclusion to Gaussian channels. Klinc *et al.* [252] propose an effective coding scheme for Gaussian wiretap channel based on LOPC codes, which is encodable in linear time. It can be combined with cryptography techniques, providing improved data security protection in communication channels. Radio frequency recognition system proposed by Sperandio *et al.* [253] can recognize the identities of transmitters from received signal. Each participant has its own intrinsic physical properties, so the system aims to process the extracted features and obtain a fingerprint for each party. Cobb *et al.* [254] used a Bayesian classifier to analyze amplitude, phase, and frequency, thus providing authentication for the communication system. Dan *et al.* propose a method using radio frequency as physical fingerprints to authenticate WiFi device's identity [255]. The approach of radio frequency fingerprints authentication is effective in the aspect of preventing network intrusion, especially when cryptography based authentication techniques are difficult to implement in some specific systems.

Power Allocation Approaches. In Wyner's wiretap channel model, the quality of eavesdropper's channel must be worse than that of legitimate user's in order to achieve communication confidentiality. But in some cases, the eavesdropper is closer to the original station than legitimate user, which means eavesdropper has a better channel quality than legitimate user. To solve this problem, Goel *et al.* [256] propose to add artificial noise to the channel to deteriorate the eavesdropper's channel, thus achieving minimum guaranteed secrecy capacity. In this method, if the original station has more antennas than eavesdropper, transmitter can use part of the power to generate artificial noise, and injected into the channel with multiple antennas. The information signal is transmitted in the range space in legitimate channel, while the artificial noise is generated in the null space in eavesdropper's channel, so the artificial noise only impairs eavesdropper's channel but not intended receiver's channel. However, this design heavily depends on the obtainment of accurate channel knowledge.

Signal Processing approaches. Shannon demonstrated that perfect secrecy can be achieved when the key space is as large as or larger than the plaintext space, such as one-time pad. But if the eavesdropper has less information than the legitimate user, communication secrecy is possible to be achieved. By analyzing the features of receiver's channels, the original station can design artificial noise to degrade the eavesdropper's channel using a multistage training-based channel estimation scheme proposed in [249]. The noise is designed to minimize the normalized mean squared error of legitimate user's channel estimation. However, the method requires that original station get the knowledge of legitimate user's channel, which can be obtained from the feedback of

legitimate user.

X. APPLICATIONS

Generally, the Internet of Things (IoT) refers to a network of connected devices (also known as smart objects) that can collect and exchange data over the internet [257]. Over the past few years, there is an emerging trend of employing artificial intelligence (AI) for IoT as AI has made lots of remarkable achievements in the big-data era [258]. To date, artificial intelligence of things (AIoT) has been widely used in various kinds of areas. With the help of 6G wireless network, the performance of AIoT systems will be greatly enhanced. In fact, many researchers have demonstrated the versatility of 6G-based AIoT systems on a wide range of scenarios. In the following, we focus on several typical applications for further illustration and summarize these works in Table VII.

A. AI in network management.

As 6G network becomes complex, it may utilize deep learning instead of human operators to improve the flexibility and efficiency in the network management [4]. AI technologies are applicable to both the physical layer and network layers. In physical layer, AI techniques have involved in design and resource allocation in wireless communications [7]. For example, unsupervised learning are applicable to interference cancellation, optimal modulation, channel-aware feature-extraction, and channel estimation, etc. [4]. Deep reinforcement learning is possible to be employed for link preservation, scheduling, transmission optimization, on-demand beamforming, and energy harvesting [4,148]. In addition, AI technologies can be used to the network layer as well. Supervised learning techniques can tackle problems such as resource allocation, fault prediction [4]. Besides, unsupervised learning algorithms can help in routing, traffic control, parameter prediction, resource allocations, etc. [4]. Reinforcement learning can be important for traffic prediction, packet scheduling, multi-objective routing, security, and classification [4,148].

B. AI in Autonomy.

AI technologies are potential to enable 6G wireless systems to be autonomous [3,108,110]. Agents with intelligence can detect and resolve network issues actively and autonomously. AI-based network management contributes to monitoring network status in real-time and keep network health. Also, AI techniques can provide intelligence at the edge devices and edge computing, which enables edge devices and edge computing to learn to solve security problems autonomously [3,232,259]. In addition, autonomous applications such as autonomous aerial vehicles and autonomous robots are envisioned to be available in 6G [7].

C. Smart Healthcare

The number of Chronic patients and the aging of population are increasing dramatically year by year [271]. Besides, traditional healthcare systems require patients to visit the hospitals, which are time-consuming and labor-intensive [272].

TABLE VII
SUMMARIZATION OF APPLICATIONS IN ARTIFICIAL INTELLIGENCE OF THINGS.

Typical applications	Reference	Requirements
Smart Healthcare	[61], [11], [19], [27], [260]	Ultra-low latency High bandwidth High security
Smart Manufacturing	[62], [12], [261], [44], [262], [263]	Ultra-low latency Ultra-high reliability Ultra-high bandwidth Very high intelligence
Smart Home	[63], [264], [263], [265]	Ultra-low latency Ultra-high security Very high intelligence
Intelligent Transportation System	[63], [266], [62], [243], [65], [267], [268], [269], [243]	Ultra-low latency Ultra-high bandwidth Ultra-high security High intelligence High mobility Long distance
Smart Grid	[64], [7]	Ultra-low latency Ultra-high security
Unmanned Aerial Vehicle	[65], [63], [11], [270], [5]	Ultra-low latency Ultra-high bandwidth Ultra-high mobility Ultra-long distance

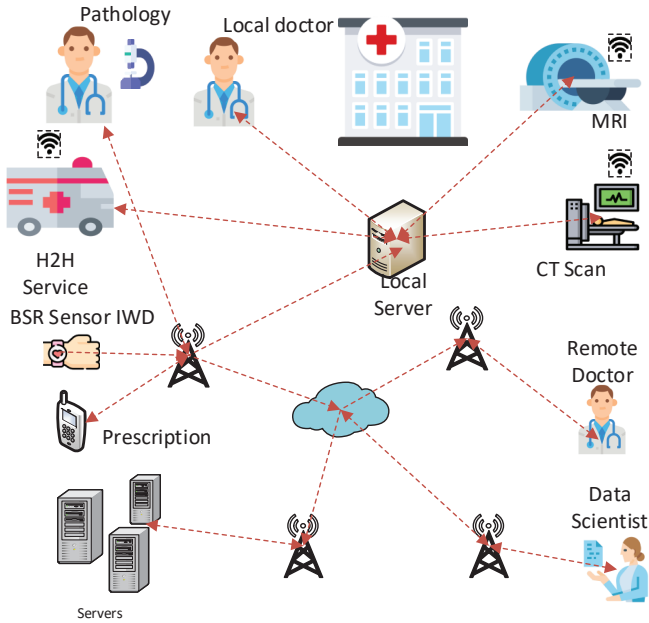

Fig. 21. Smart Healthcare.

Therefore, healthcare systems improvement is significant for people’s wellbeing. An efficient healthcare system is expected to carry out health monitoring, disease diagnosis, and medical treatment remotely with high efficiency. To this end, researchers have resorted to smart healthcare. Smart healthcare is a healthcare service system that combines a variety of technologies such as wearable sensors and AIoT [273]. Smart healthcare can not only provide convenience for the people but also save lives in emergency. Even though time and space are barriers of current healthcare systems, 6G wireless network enables smart healthcare to overcome these barriers. Therefore,

6G allows healthcare systems to complete more useful and sophisticated tasks as illustrated in 21. That is, patients can be accurately diagnosed and treated by professional doctors even if they are at home.

Health Monitoring and Disease Detection. Continuous health status monitoring is crucial in healthcare service, especially for those patients who suffer from sudden disease (e.g., cardiovascular diseases). In 6G-based healthcare systems, data-driven models that can detect abnormal health status will be uploaded on the cloud in advance. Patients’ physiological data can be collected continuously by noninvasive sensors and will be transmitted to the cloud. The models on the cloud will analyse the data and send a warning message if the diseases occur suddenly. 6G technology will play a critical role as both real-time monitoring and disease notification require high data rates to react quickly. What’s more, 6G will prompt the development of the hospital-to-home (H2H) service to replace the traditional ambulance service [61].

Medical Treatment. The merits of 6G will support doctors to perform more effective medical treatment. For example, augmented reality (AR) and virtual reality (VR) can be applied in medical treatment because of high data rates and low latency in 6G communication. To be more specific, AR enables doctors to observe the inside of the patient’s body clearly without making any incision, while VR can help doctors to practice medical operations in a simulated environment [61].

6G also revitalizes the medical robots [11]. For example, the medical robots will take care of the patients and provide timely help for them when the hospital is too busy and most nurses are unavailable. Besides, the medical robots will help doctors in surgeries as the 6G wireless network allows the robots to carry out complex tasks with high precision. Specifically, the size of the medical robots can be very small so that the doctors will control them to enter the human’s body to take pictures, deliver drugs, or remove diseased tissues.

Privacy and Security in Healthcare. Security and privacy are one of the important challenges of 6G technology as well as the key concerns for the patients [19]. Edge computing can be used to protect patients' privacy [61]. The data will be delivered to different edge nodes because the memory of edge nodes is small. Therefore, healthcare data do not need to be stored in only one place, hence increasing the communication security. Besides, selectively uploading the data to the cloud helps to improve security as it's easier for the cloud to protect lesser data [61]. Last but not least, blockchains or federated learning are also possible approaches to address the privacy problem in healthcare systems in the future [27,260].

D. Smart Manufacturing

Industry 4.0 has envisioned a digital transformation of manufacturing through cyber physical systems and IoT services, and its main goal is to reduce human intervention in industrial processes by using efficient control approaches and communication technologies [44]. 6G will finally realize this revolution by investigating smart manufacturing [62]. Smart manufacturing refers to a IoT-connected manufacturing system that applies a variety of control and data analytics approaches to improve manufacturing performance. The advantages of 6G will boost the communication and computing capabilities of the connected sensors and machinery, thus leading to a preciser and smarter manufacturing system [12].

High-precision Manufacturing. It is vital for the manufacturing system to maintain high precision during operations. Numerically speaking, implementing high-precision manufacturing requires very high reliability (up to about 10^9) and extremely low latency (0.1 to 1ms round trip time) [261]. In addition, massive amounts of data and transmissions are involved in industrial control networks, hence requiring a very low delay jitter (about $1\mu s$) [261].

The above requirements can hardly be met if using 5G technology. In contrast, the emergence of 6G paves the way for high-precision manufacturing because of its superior features. For example, a new 6G-based architecture that integrates different resources has been proposed to satisfy the tight physical constraints [44]. Some researchers also resorts to other advanced IoT approaches, such as blockchain [262] and edge computing [263], in order to improve the performance of the manufacturing systems.

Intelligent Robots. In a modern manufacturing system, it is very common to apply intelligent robots to deal with dull and tedious work. In addition, the robots can also replace human to carry out dangerous industrial operation or the tasks that require extremely high precision. According to Industry 4.0, the robots are required to react quickly when interacting with humans and machinery in a dynamic environment [274]. To this end, it is very necessary to apply 6G technology into robotics communication [61].

The intelligent robots connected by 6G wireless network robots will be able to conduct complex cooperative operations [263,275]. For example, intelligent robots on the edge side can take videos of the industrial process and then upload the data to the cloud, while the learning algorithms on the

cloud will make decisions to control the robots. Aided by 6G technology, the robots will be competent enough even though the whole control loop requires ultrahigh data rates. As a result, sensors, robots, machinery, and 6G will form an efficient distributed intelligent network which has terabytes of computing capacity [104]. Furthermore, there are some manufacturing processes which are hazardous but still require high precision, such as nuclear power plants and oil pipelines. In this case, nano-robots can be used in those dangerous environments [276].

E. Smart Home

A smart home contains different kinds of IoT devices and AI-driven in-network services to remotely control the household systems like lighting, furniture, and thermostats [263]. Current smart homes have been able to control the furniture and house environment according to people's commands. In the future, 6G will allow the household systems to be smarter, like providing adaptive real-time control without much human intervention. In addition to the convenience, residents' safety and privacy will also be well protected using 6G technologies such as federated learning.

Intelligent Furniture. Intelligent furniture in the smart home will facilitate people's life as well as save energy. To begin with, an intelligent light will switch off when nobody occupies the room, and the light intensity can be continuously tuned according to sunlight intensity [63]. Over time, this will save substantial electrical energy while people do not have to pay extra attention to this matter. Similarly, the air conditioner can work based on the indoor temperature and occupancy detection. Furthermore, the running data of furniture can be recorded on the cloud side so that individual preferences can be learned by AI algorithms. Under this circumstance, the intelligent furniture will be tuned with the considering of individual preferences, thus leading to a comfortable home. Noted that real-time control, occupancy detection, and individual preferences estimation will generate a large amount of data and requires higher capacity requirements. Therefore, 6G is essential for the implementation of intelligent furniture.

Emergency Detection. 6G will aid the smart homes in emergency detection so as to keep residents' safe. For example, fall detection of the elderly is a major public health challenge [264]. If an old man suddenly falls down in a smart home, the data collected by embedded intelligent sensors and video surveillance will be sent to the cloud by 6G wireless network immediately. The well-trained prediction model on the cloud side should detect this emergency by analysing the data and then send distress signals to the man's relatives and the ambulance. Other kinds of emergencies, such as forced entry and fire, can be detected easily by a similar method.

Privacy Protection. Privacy sensitive data are frequently transmitted in the smart home, hence requiring a reliable privacy protection approach. Some researchers tackled the privacy problems through edge-native solutions [263], which means data storage and processing will be done within the residents' premises. In [265], an AI based adaptive security specification method for 6G IoT networks has been proposed

to address the privacy problems, and the proposed method has been evaluated in a smart room.

F. Intelligent Transportation System

The intelligent transportation system (ITS) utilizes advanced communication, control, and sensing technologies to provide safer and efficient traffic and traffic management. In a ITS, autonomous driving vehicles require reliability above 99.99999% and latency below 1 ms, while the vehicle speed in some cases can be as high as to 1000 km/h [12,44]. However, the ITS fails to meet these requirements in such high mobility scenarios because of the insufficient capability of the current communication technologies. In contrast, 6G network will significantly improve the capability of the ITS and make it satisfy the strict requirements.

Traffic Management. An effective traffic management approach can force down the traffic jams, reduce passengers' waiting time, and preserve the road security. In order to provide real time transportation planning, the traffic information has to be collected in high data rates. Besides, the global optimal solution will be obtained only if the coverage of the mobile communication network is large enough. Thus, it is necessary to apply 6G technology in traffic management owing to its high speed internet, low latency, and extensive coverage [63]. The ITS empowered by 6G will keep guiding the drivers so as to minimize the travel time. It is also promising to investigate 6G for traffic signal control problems since traffic signal control involves a massive amount of real time traffic data and requires sophisticated algorithms to make decisions [266]. Last but not least, 6G technology will enhance the public traffic security. Police can utilize vehicle surveillance to track a suspected vehicle [63]. The parameters and components of the vehicles will be continuously monitored to ensure safe driving.

Autonomous Vehicles. Autonomous vehicles is one of the key applications in the ITS [277]. Compared with the traffic management, the implementation of autonomous vehicles requires even higher data rates [62]. 6G will help autonomous vehicles overcome the physical barriers and realize full automation. Advanced communication methods, such as dedicated short-range communication (DSRC), vehicle-to-network (V2N), vehicle-to-infrastructure (V2I), vehicle-to-Pedestrian (V2P), Vehicle-to-Home (V2H), and vehicle-to-everything (V2X), have great potential to formulate a comprehensive autonomous vehicle network [243]. Besides, novel AI approaches, like real-time intelligent edge, are indispensable for vehicle networks implementation as they enable the autonomous vehicles to react to the unfamiliar environment in real time [65]. In addition to improving the speed, users' privacy will be better protected in the next generation autonomous vehicles. For example, a Efficient and Privacy-preserving Truth Discovery (EPTD) method is developed to strengthen the privacy protection [267]. Also, researchers solve the security problems of vehicular Ad-hoc Networks (VANETs) by designing a privacy preserving machine learning-based collaborative intrusion detection system [267,268].

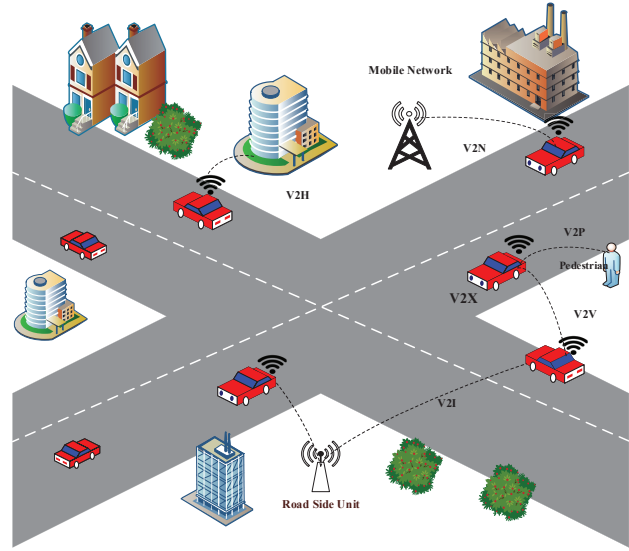

Fig. 22. Vehicle-to-Everything (V2X).

Airport and Waterway Transportation. In addition to the land transportation, the applicability of 6G technology will expand into airport and waterway transportation. By integrating with satellite communication, 6G can provide localization services, broadcast, Internet connectivity, and weather information to cellular users [4]. Satellite communication has potential benefits, such as providing readily connection to moving objects, and it is expected to be used in wireless network architectures in the future. Specifically, the global coverage provided by 6G enables the ships and airplanes to be connected with a variety of IoT devices, which leads to a more intelligent transportation system. With the ubiquitous connectivity, 6G can keep updating the weather condition to the captains, which ensures the transportation safety [63]. Besides, the satellite communication can be applied to connect the land, air, and sea together into an integrated 6G system [269]. For instance, AANETs, which is proposed in [278], demonstrated the feasibility of satellite communication in transport network. Moreover, optical wireless communication, such as free space optics (FSO) [243] and visible light communication (VLC) [62], will also be useful in airport and waterway transportation.

G. Smart Grid

Smart grid is an IoT-based electricity network that utilizes advanced communication and AI methods to deliver power in more efficient ways [64]. Researchers have been working on integrating 5G into the smart grid [7], yet few people have considered applying 6G communication into this area. In the near future, however, 6G will be an indispensable technology for the further development of smart grid due to the fact that smart grid systems will demand more extensive computations and higher data rates.

In a smart grid system, all activities and electrical equipment should be supervised in order to make sure the system runs

smoothly and safely. 6G enables smart grid systems that contain a great number of IoT devices to conduct real-time remote monitoring and control. Moreover, because of ultra reliability and low latency of 6G, the electricity network will be able to detect the fault quickly and then take actions in time. In addition, by employing 6G technology, the scale of the smart grid can be greatly extended without sacrificing the control precision and increasing the communication latency.

H. Unmanned Aerial Vehicle

The operation of unmanned aerial vehicle (UAV) requires either manual control or autonomous control by intelligent algorithms. Both two control approaches need exchange large amounts of data every second. Moreover, UAV is usually expected to carry out tasks in a long distance at high altitudes, which requires the wireless network to have high data rates and large coverage. Even though UAV cannot be applied successfully in the 5G network, 6G technology will facilitate the implementation of UAV due to the high capabilities of 6G [65].

UAV will be used as an aerial base station (BS) in 6G wireless communication owing to its aerial superiority. By using Drone-to-Drone (D2D) and Drone-to-Infrastructures (D2I) communication, the 6G network will maintain high data rate while extending the wireless coverage [63]. Besides the coverage, UAV has several advantages over fixed BS infrastructures, such as easy deployment, strong line-of-sight links, and high mobility [11,270]. Therefore, UAV can be used as a flexible and low-latency BS in the areas where the infrastructures are absent or heavily loaded. For instance, natural disasters can destroy the ground communication infrastructures, and it is very difficult to establish new infrastructures in such a hazardous place [5]. In this case, UAV-supported aerial base station will provide stable wireless connectivity.

I. Smart and Autonomous Communication Systems

In this section, we present some potential use cases of AI in 6G such as AI in network management and AI in autonomy. As 6G network becomes complex, it may utilize deep learning instead of human operators to improve the flexibility and efficiency in the network management [4]. AI technologies are applicable to both the physical layer and network layers. In physical layer, AI techniques have involved in design and resource allocation in wireless communication [7]. For example, unsupervised learning are applicable to channel-aware feature-extraction, optimal modulation, interference cancellation, and channel estimation, etc. [4]. Deep reinforcement learning is possible to be employed for link preservation, scheduling, transmission optimization, on-demand beamforming, and energy harvesting, etc. [4,148]. In addition, AI technologies can be used to the network layer as well. Supervised learning techniques can tackle problems such as resource allocation, fault prediction, etc. [4]. Besides, unsupervised learning algorithms can help in routing, traffic control, parameter prediction, resource allocations, etc. [4]. Reinforcement learning can be important for traffic prediction, packet scheduling, multi-objective routing, security, and classification, etc. [4,148].

In addition, AI technologies have potentials to enable 6G wireless systems to be autonomous [3,108,110]. Agents with intelligence can detect and resolve network issues actively and autonomously. AI-based network management contributes to monitoring network status in real-time and keep network healthy. Also, AI techniques can provide intelligence at the edge devices and edge computing, which enables edge devices and edge computing to learn to solve security problems autonomously [3,232,259]. Besides, autonomous applications such as autonomous aerial vehicles and autonomous robots are envisioned to be available in 6G [7].

J. Intelligent Vehicle-to-Everything Communications

The vehicular network builds the bridge between human beings and transportation [113], for example, vehicle-to-vehicle shown in Fig. 22. As the number of vehicles is increasing rapidly, the over crowded vehicular network fails to achieve high latency and low reliability. While traditional vehicular networks attach great attention to vehicle-to-vehicle (V2V) and vehicle-to-infrastructure (V2I) communications, the 6G vehicular network will realize space-air-ground-sea even underwater vehicles.

Although 5G technology has spanned over network function virtualization (NFV), cognitive radio (CR), and reactive vehicular network control, they cannot meet the requirements of 6G communications. 6G requires to evolve to network intelligentization, intelligent radio, and self-learning with proactive exploration. Aided by advanced automation techniques and sensitive collision avoidance ability, the performance of vehicular networks can be significantly enhanced in 6G era.

XI. CONCLUSION

In this paper, we highlight some promising technologies in 6G networks. We present a detailed explanation of artificial intelligence, intelligent reflecting surfaces, SWIFT, THz communications, blockchain, space-air-ground-sea integrated network, full-duplex technologies and how these technologies will be applied in 6G. In addition, we discuss the potential security and privacy problems brought by these technologies. Moreover, we envision that 6G will enable a large sum of new application in facilitating our life.

REFERENCES

- [1] J. Wills, "5G technology: Which country will be the first to adapt?" <https://www.investopedia.com/articles/markets-economy/090916/5g-technology-which-country-will-be-first-adapt.asp>, April 23, 2020.
- [2] L. Matti and L. Kari, "Key drivers and research challenges for 6G ubiquitous wireless intelligence," *6G Flagship, Oulu, Finland, White Paper*, 2019.
- [3] L. Lovén, T. Leppänen, E. Peltonen, J. Partala, E. Harjula, P. Poram-bage, M. Ylianttila, and J. Riekkki, "EdgeAI: A vision for distributed, edge-native artificial intelligence in future 6G networks," *The 1st 6G Wireless Summit*, pp. 1–2, 2019.
- [4] M. J. Piran and D. Y. Suh, "Learning-Driven wireless communications, towards 6G," in *2019 International Conference on Computing, Electronics and Communications Engineering (ICCECE)*. IEEE, 2019, pp. 219–224.
- [5] M. Z. Chowdhury, M. Shahjalal, S. Ahmed, and Y. M. Jang, "6G wireless communication systems: Applications, requirements, technologies, challenges, and research directions," *IEEE Open Journal of the Communications Society*, vol. 1, pp. 957–975, 2020.

- [6] W. Saad, M. Bennis, and M. Chen, "A vision of 6G wireless systems: Applications, trends, technologies, and open research problems," *IEEE network*, vol. 34, no. 3, pp. 134–142, 2019.
- [7] T. M. Ho, T. D. Tran, T. T. Nguyen, S. Kazmi, L. B. Le, C. S. Hong, and L. Hanzo, "Next-generation wireless solutions for the smart factory, smart vehicles, the smart grid and smart cities," *arXiv preprint arXiv:1907.10102*, 2019.
- [8] M. B. Mollah, S. Zeadally, and M. A. K. Azad, "Emerging wireless technologies for Internet of Things applications: Opportunities and challenges," in *Encyclopedia of Wireless Networks*. Springer International Publishing Cham, 2019, pp. 1–11.
- [9] M. Giordani and M. Zorzi, "Satellite communication at millimeter waves: A key enabler of the 6G era," in *2020 International Conference on Computing, Networking and Communications (ICNC)*. IEEE, 2020, pp. 383–388.
- [10] K. David, J. Elmırghani, H. Haas, and X.-H. You, "Defining 6G: Challenges and opportunities [from the guest editors]," *IEEE Vehicular Technology Magazine*, vol. 14, no. 3, pp. 14–16, 2019.
- [11] F. Tariq, M. R. Khandaker, K.-K. Wong, M. A. Imran, M. Bennis, and M. Debbah, "A speculative study on 6G," *IEEE Wireless Communications*, vol. 27, no. 4, pp. 118–125, 2020.
- [12] M. Giordani, M. Polese, M. Mezzavilla, S. Rangan, and M. Zorzi, "Toward 6G networks: Use cases and technologies," *IEEE Communications Magazine*, vol. 58, no. 3, pp. 55–61, 2020.
- [13] M. Xiao, S. Mumtaz, Y. Huang, L. Dai, Y. Li, M. Matthaiou, G. K. Karagiannidis, E. Björnson, K. Yang, I. Chih-Lin, and A. Ghosh, "Millimeter wave communications for future mobile networks," *IEEE Journal on Selected Areas in Communications*, vol. 35, no. 9, pp. 1909–1935, 2017.
- [14] J. G. Andrews, T. Bai, M. N. Kulkarni, A. Alkhateeb, A. K. Gupta, and R. W. Heath, "Modeling and analyzing millimeter wave cellular systems," *IEEE Transactions on Communications*, vol. 65, no. 1, pp. 403–430, 2016.
- [15] L. Zhu, Z. Xiao, X.-G. Xia, and D. O. Wu, "Millimeter-wave communications with non-orthogonal multiple access for B5G/6G," *IEEE Access*, vol. 7, pp. 116 123–116 132, 2019.
- [16] S. J. Nawaz, S. K. Sharma, S. Wyne, M. N. Patwary, and M. Asaduzzaman, "Quantum machine learning for 6G communication networks: State-of-the-art and vision for the future," *IEEE Access*, vol. 7, pp. 46 317–46 350, 2019.
- [17] Y. Corre, G. Gougeon, J.-B. Doré, S. Bicaïs, B. Miscopein, E. Fausurier, M. Saad, J. Palicot, and F. Bader, "Sub-THz spectrum as enabler for 6G wireless communications up to 1 Tbit/s," 2019.
- [18] S. Underwood, "Blockchain beyond bitcoin," 2016.
- [19] S. Dang, O. Amin, B. Shihada, and M.-S. Alouini, "What should 6G be?" *Nature Electronics*, vol. 3, no. 1, pp. 20–29, 2020.
- [20] N. Kato, B. Mao, F. Tang, Y. Kawamoto, and J. Liu, "Ten challenges in advancing machine learning technologies toward 6G," *IEEE Wireless Communications*, 2020.
- [21] R. Shafin, L. Liu, V. Chandrasekhar, H. Chen, J. Reed, and J. C. Zhang, "Artificial intelligence-enabled cellular networks: A critical path to beyond-5G and 6G," *IEEE Wireless Communications*, vol. 27, no. 2, pp. 212–217, 2020.
- [22] J. Tan and L. Dai, "THz precoding for 6G: Applications, challenges, solutions, and opportunities," *arXiv preprint arXiv:2005.10752*, 2020.
- [23] S. Elmeadawy and R. M. Shubair, "Enabling technologies for 6G future wireless communications: Opportunities and challenges," *arXiv preprint arXiv:2002.06068*, 2020.
- [24] G. Gui, M. Liu, F. Tang, N. Kato, and F. Adachi, "6G: Opening new horizons for integration of comfort, security and intelligence," *IEEE Wireless Communications*, 2020.
- [25] S. Chen, Y.-C. Liang, S. Sun, S. Kang, W. Cheng, and M. Peng, "Vision, requirements, and technology trend of 6G: how to tackle the challenges of system coverage, capacity, user data-rate and movement speed," *IEEE Wireless Communications*, vol. 27, no. 2, pp. 218–228, 2020.
- [26] X. You, C. Wang, J. Huang, X. Gao, Z. Zhang, M. Wang, Y. Huang, C. Zhang, Y. Jiang, J. Wang, M. Zhu, B. Sheng, D. Wang, Z. Pan, P. Zhu, Y. Yang, Z. Liu, P. Zhang, X. Tao, S. Li, Z. Chen, X. Ma, C. I. S. Han, K. Li, C. Pan, Z. Zheng, L. Hanzo, X. Shen, Y. J. Guo, Z. Ding, H. Haas, W. Tong, P. Zhu, G. Yang, J. Wang, E. G. Larsson, H. Ngo, W. Hong, H. Wang, D. Hou, J. Chen, Z. Chen, Z. Hao, G. Li, R. Tafazolli, Y. Gao, V. Poor, G. Fettweis, and Y. Liang, "Towards 6G wireless communication networks: Vision, enabling technologies, and new paradigm shifts," *SCIENCE CHINA Information Sciences*. [Online]. Available: <https://engine.scichina.com/publisher/ScienceChinaPress/journal/SCIENCECHINAInformationSciences///10.1007/s11432-020-2955-6>
- [27] S. Nayak and R. Patgiri, "6G: Envisioning the key issues and challenges," *arXiv preprint arXiv:2004.04024*, 2020.
- [28] Y. A. Chau and S. H. Yu, "Space modulation on wireless fading channels," in *IEEE 54th Vehicular Technology Conference. VTC Fall 2001. Proceedings*. IEEE, 2001, pp. 1668–1671.
- [29] A. Li, Y. Ma, S. Xue, N. Yi, R. Tafazolli, and T. Dodgson, "Unsupervised deep learning for blind multiuser frequency synchronization in OFDMA uplink," in *2019 IEEE International Conference on Communications (ICC)*. IEEE, 2019, pp. 1–6.
- [30] X. Shen, J. Gao, W. Wu, K. Lyu, M. Li, W. Zhuang, X. Li, and J. Rao, "AI-assisted network-slicing based next-generation wireless networks," *IEEE Open Journal of Vehicular Technology*, vol. 1, pp. 45–66, 2020.
- [31] S. Hu, F. Rusek, and O. Edfors, "Beyond massive MIMO: the potential of data transmission with large intelligent surfaces," *IEEE Transactions on Signal Processing*, vol. 66, no. 10, pp. 2746–2758, 2018.
- [32] —, "The potential of using large antenna arrays on intelligent surfaces," in *IEEE 2017 Vehicular Technology Conference (VTC)*. IEEE, 2017, pp. 1–6.
- [33] Q. Wu and R. Zhang, "Intelligent reflecting surface enhanced wireless network via joint active and passive beamforming," *IEEE Transactions on Wireless Communications*, vol. 18, no. 11, pp. 5394–5409, 2016.
- [34] H. Wang, W. Wang, and X. Chen, "Wireless information and energy transfer in interference aware massive MIMO systems," in *2014 IEEE Global Communications Conference*. IEEE, 2014, pp. 2556–2561.
- [35] R. Zhang, R. G. Maunder, and L. Hanzo, "Wireless information and power transfer: from scientific hypothesis to engineering practice," *IEEE Communications Magazine*, vol. 53, no. 8, pp. 99–105, 2015.
- [36] Y. Liu, Z. Ding, and M. Elkashlan, "Cooperative non-orthogonal multiple access with simultaneous wireless information and power transfer," *IEEE Journals on Selected Areas in Communications*, vol. 34, no. 4, pp. 938–953, 2016.
- [37] Z. Yang, Z. Ding, P. Fan, and N. Al-Dhahir, "The impact of power allocation on cooperative non-orthogonal multiple access networks with SWIPT," *IEEE Transactions on Wireless Communications*, vol. 16, no. 7, pp. 4332–4343, 2017.
- [38] J. Gong and X. Chen, "Achievable rate region of non-orthogonal multiple access systems with wireless powered decoder," *IEEE Journals on Selected Areas in Communications*, vol. 35, no. 12, pp. 2846–2859, 2017.
- [39] Y. Alsaba, C. Y. Leow, and S. K. A. Rahim, "Full-duplex cooperative non-orthogonal multiple access with beamforming and energy harvesting," *IEEE Access*, vol. 6, pp. 19726–19738, 2018.
- [40] L. Bariah, S. Muhaidat, and A. A. Dweik, "Error probability analysis of NOMA-based relay networks with SWIPT," *IEEE Access*, vol. 23, no. 7, pp. 1223–1226, 2019.
- [41] S. Li, L. Bariah, S. Muhaidat, P. Sofotasios, J. Liang, and A. Wang, "Error analysis of NOMA-based user cooperation with SWIPT," in *2019 15th International Conference on Distributed Computing in Sensor Systems (DCOSS)*. IEEE, 2019, pp. 507–513.
- [42] L. Subrt and P. Pechac, "Controlling propagation environments using intelligent walls," in *2012 6th European Conf. Antennas Propag. (EUCAP)*. EUCAP, 2012, pp. 1–5.
- [43] H. Haas, "LiFi is a paradigm-shifting 5G technology," *Reviews in Physics*, vol. 3, pp. 26–31, 2018.
- [44] E. C. Strinati, S. Barbarossa, J. L. Gonzalez-Jimenez, D. Ktenas, N. Cassiau, L. Maret, and C. Dehos, "6G: The next frontier: From holographic messaging to artificial intelligence using subterahertz and visible light communication," *IEEE Vehicular Technology Magazine*, vol. 14, no. 3, pp. 42–50, 2019.
- [45] U. N. Kar and D. K. Sanyal, "A critical review of 3GPP standardization of device-to-device communication in cellular networks," *SN Computer Science*, vol. 1, no. 1, p. 37, 2020.
- [46] P. K. Malik, D. S. Wadhwa, and J. S. Khinda, "A survey of device to device and cooperative communication for the future cellular networks," *International Journal of Wireless Information Networks*, pp. 1–22, 2020.
- [47] A. Asadi, Q. Wang, and V. Mancuso, "A survey on device-to-device communication in cellular networks," *IEEE Communications Surveys & Tutorials*, vol. 16, no. 4, pp. 1801–1819, 2014.
- [48] Y. Zhang, E. Pan, L. Song, W. Saad, Z. Dawy, and Z. Han, "Social network aware device-to-device communication in wireless networks," *IEEE Transactions on Wireless Communications*, vol. 14, no. 1, pp. 177–190, 2014.

- [49] S. Zhang, H. Zhang, and L. Song, "Beyond D2D: Full dimension UAV-to-everything communications in 6G," *IEEE Transactions on Vehicular Technology*, 2020.
- [50] W. paper, "5G evolution and 6G," in *NTT DOCOMO, INC.*, 2020.
- [51] H. Xu, P. V. Klainea, O. Oniretia, B. Caob, M. Imrana, and L. Zhang, "Blockchain-enabled resource management and sharing for 6G communications," *arXiv preprint arXiv:2003.13083*, 2020.
- [52] K. Fan, Y. Ren, Y. Wang, H. Li, and Y. Yang, "Blockchain-based efficient privacy preserving and data sharing scheme of content-centric network in 5G," *IET Communications*, vol. 12, no. 5, pp. 527–532, 2017.
- [53] K. Kotobi and S. G. Bilen, "Secure blockchains for dynamic spectrum access: A decentralized database in moving cognitive radio networks enhances security and user access," *IEEE vehicular technology magazine*, vol. 13, no. 1, pp. 32–39, 2018.
- [54] H. Yang, H. Zheng, J. Zhang, Y. Wu, Y. Lee, and Y. Ji, "Blockchain-based trusted authentication in cloud radio over fiber network for 5G," in *2017 16th International Conference on Optical Communications and Networks (ICON)*. IEEE, 2017, pp. 1–3.
- [55] I. Tomkos, D. Klonidis, E. Pikasis, and S. Theodoridis, "Toward the 6G network era: Opportunities and challenges," *IT Professional*, vol. 22, no. 1, pp. 34–38, 2020.
- [56] N. Akhtar and A. Mian, "Threat of adversarial attacks on deep learning in computer vision: A survey," *IEEE Access*, vol. 6, pp. 14 410–14 430, 2018.
- [57] B. McMahan, E. Moore, D. Ramage, S. Hampson, and B. A. y Arcas, "Communication-efficient learning of deep networks from decentralized data," in *Artificial Intelligence and Statistics*. PMLR, 2017, pp. 1273–1282.
- [58] Z. Zhou, H. Liao, B. Gu, K. M. S. Huq, S. Mumtaz, and J. Rodriguez, "Robust mobile crowd sensing: When deep learning meets edge computing," *IEEE Network*, vol. 32, no. 4, pp. 54–60, 2018.
- [59] R. Sattiraju, A. Weinand, and H. D. Schotten, "AI-assisted PHY technologies for 6G and beyond wireless networks," *arXiv preprint arXiv:1908.09523*, 2019.
- [60] K. B. Letaief, W. Chen, Y. Shi, J. Zhang, , and Y. A. Zhang, "The roadmap to 6G: Ai empowered wireless networks," *IEEE Communications Magazine*, vol. 57, no. 8, pp. 84–90, 2019.
- [61] S. Nayak and R. Patgiri, "6G communication technology: A vision on intelligent healthcare," *arXiv preprint arXiv:2005.07532*, 2020.
- [62] N. Rajatheva, I. Atzeni, E. Bjornson, A. Bourdoux, S. Buzzi, J.-B. Dore, S. Erkkucuk, M. Fuentes, K. Guan, Y. Hu, X. Huang, J. Hukkkonen, J. M. Jornet, M. Katz, R. Nilsson, E. Panayirci, K. Rabie, N. Rajapaksha, M. Salehi, H. Sameddeen, T. Svensson, O. Tervo, A. Togli, Q. Wu, and W. Xu, "White paper on broadband connectivity in 6G," *arXiv preprint arXiv:2004.14247*, 2020.
- [63] S. Nayak and R. Patgiri, "6G communications: A vision on the potential applications," *arxiv*, 04 2020.
- [64] X. Fang, S. Misra, G. Xue, and D. Yang, "Smart grid — the new and improved power grid: A survey," *Communications Surveys & Tutorials, IEEE*, vol. 14, pp. 944–980, 01 2012.
- [65] M. Wang, T. Zhu, T. Zhang, J. Zhang, S. Yu, and W. Zhou, "Security and privacy in 6G networks: New areas and new challenges," *Digital Communications and Networks*, vol. 6, 07 2020.
- [66] Y. Yang, "Spatial modulation exploited in non-reciprocal two-way relay channels: Efficient protocols and capacity analysis," *IEEE Transactions on Wireless Communications*, vol. 64, no. 7, pp. 2821–2834, 2016.
- [67] N. R. Naidoo, H. J. Xu, and T. A. Quazi, "Spatial modulation: optimal detector asymptotic performance and multi-stage detection," *IET Communications*, vol. 5, no. 10, pp. 1368–1376, 2011.
- [68] S. Sugiura, C. Xu, S. X. Ng, and L. Hanzo, "Reduced-complexity coherent versus non-coherent QAM-aided space-time shift keying," *IEEE Transactions on communications*, vol. 59, no. 11, pp. 3090–3101, 2011.
- [69] C. Li, Y. Huang, M. Di Renzo, J. Wang, and Y. Cheng, "Low-complexity ml detection for spatial modulation MIMO with APSK constellation," *IEEE Transactions on Vehicular Technology*, vol. 64, no. 9, pp. 4315–4321, 2015.
- [70] M. Maleki, H. R. Bahrami, and A. Alizadeh, "On MRC-based detection of spatial modulation," *IEEE Transactions on Wireless Communications*, vol. 15, no. 4, pp. 3019–3029, 2016.
- [71] L. Xiao, P. Yang, Y. Xiao, S. Fan, M. Di Renzo, W. Xiang, and S. Li, "Efficient compressive sensing detectors for generalized spatial modulation systems," *IEEE Transactions on Vehicular Technology*, vol. 66, no. 2, pp. 1284–1298, 2016.
- [72] W. Liu, N. Wang, M. Jin, and H. Xu, "Denoising detection for the generalized spatial modulation system using sparse property," *IEEE Communications letters*, vol. 18, no. 1, pp. 22–25, 2013.
- [73] C.-M. Yu, S.-H. Hsieh, H.-W. Liang, C.-S. Lu, W.-H. Chung, S.-Y. Kuo, and S.-C. Pei, "Compressed sensing detector design for space shift keying in MIMO systems," *IEEE Communications Letters*, vol. 16, no. 10, pp. 1556–1559, 2012.
- [74] A. Younis, S. Sinanovic, M. Di Renzo, R. Mesleh, and H. Haas, "Generalised sphere decoding for spatial modulation," *IEEE Transactions on Communications*, vol. 61, no. 7, pp. 2805–2815, 2013.
- [75] A. Younis, M. Di Renzo, R. Mesleh, and H. Haas, "Sphere decoding for spatial modulation," in *2011 IEEE International Conference on Communications (ICC)*. IEEE, 2011, pp. 1–6.
- [76] Y. Xiao, Z. Yang, L. Dan, P. Yang, L. Yin, and W. Xiang, "Low-complexity signal detection for generalized spatial modulation," *IEEE Communications Letters*, vol. 18, no. 3, pp. 403–406, 2014.
- [77] C. E. Chen, C. H. Li, and Y. H. Huang, "An improved ordered-block MMSE detector for generalized spatial modulation," *IEEE Communication Letters*, vol. 19, no. 5, pp. 707–710, 2015.
- [78] N. Ishikawa, S. Sugiura, and L. Hanzo, "Subcarrier-index modulation aided OFDM—will it work?" *IEEE Access*, vol. 4, pp. 2580–2593, 2016.
- [79] T. Mao, Z. Wang, Q. Wang, S. Chen, and L. Hanzo, "Dual-mode index modulation aided OFDM," *IEEE Access*, vol. 5, pp. 50–60, 2016.
- [80] T. Mao, Q. Wang, Z. Wang, and S. Chen, "Novel index modulation techniques: A survey," *IEEE Communications Surveys & Tutorials*, vol. 21, no. 1, pp. 315–348, 2018.
- [81] G. Lee and G. Schroeder, "Optical pulse position modulation with multiple positions per pulsewidth," *IEEE Transactions on Communications*, vol. 25, no. 3, pp. 360–364, 1977.
- [82] S. Sugiura, S. Chen, and L. Hanzo, "Coherent and differential space-time shift keying: A dispersion matrix approach," *IEEE Transactions on Communications*, vol. 58, no. 11, pp. 3219–3230, 2010.
- [83] —, "Generalized space-time shift keying designed for flexible diversity-, multiplexing-and complexity-tradeoffs," *IEEE Transactions on Wireless Communications*, vol. 10, no. 4, pp. 1144–1153, 2011.
- [84] E. Seifi, M. Atamanesh, and A. K. Khandani, "Media-based MIMO: Outperforming known limits in wireless," in *2016 IEEE International Conference on Communications (ICC)*. IEEE, 2016, pp. 1–7.
- [85] Z. Boudia, H. El-Sallabi, A. Ghayeb, and K. A. Qaraqe, "Reconfigurable antenna-based space-shift keying (SSK) for MIMO rician channels," *IEEE Transactions on Wireless Communications*, vol. 15, no. 1, pp. 446–457, 2015.
- [86] Y. Naresh and A. Chockalingam, "On media-based modulation using RF mirrors," *IEEE Transactions on Vehicular Technology*, vol. 66, no. 6, pp. 4967–4983, 2016.
- [87] E. Basar and I. Altunbas, "Space-time channel modulation," *IEEE Transactions on Vehicular Technology*, vol. 66, no. 8, pp. 7609–7614, 2017.
- [88] M. Koca and H. Sari, "Precoding for spatial modulation against correlated fading channels," *IEEE Transactions on Wireless Communications*, vol. 17, no. 9, pp. 5857–5870, 2018.
- [89] R. Mesleh, M. Di Renzo, H. Haas, and P. M. Grant, "Trellis coded spatial modulation," *IEEE Transactions on Wireless Communications*, vol. 9, no. 7, pp. 2349–2361, 2010.
- [90] E. Basar, U. Aygolu, E. Panayirci, and H. V. Poor, "New trellis code design for spatial modulation," *IEEE transactions on Wireless Communications*, vol. 10, no. 8, pp. 2670–2680, 2011.
- [91] Y. Naresh and A. Chockalingam, "A low-complexity maximum-likelihood detector for differential media-based modulation," *IEEE Communication Letters*, vol. 21, no. 10, pp. 2158–2161, 2015.
- [92] M. Wen, E. Basar, Q. Li, B. Zheng, and M. Zhang, "Multiple-mode orthogonal frequency division multiplexing with index modulation," *IEEE Transactions on Communications*, vol. 65, no. 9, pp. 3892–3906, 2017.
- [93] R. Mesleh, S. S. Ikki, and H. M. Aggoune, "Quadrature spatial modulation," *IEEE Transactions on Vehicular Technology*, vol. 64, no. 6, pp. 2738–2742, 2015.
- [94] J. Liu, L. Dan, P. Yang, L. Xiao, F. Yu, and Y. Xiao, "High-rate APSK-aided differential spatial modulation: Design method and performance analysis," *IEEE Communications Letters*, vol. 21, no. 1, pp. 168–171, 2016.
- [95] B. Zheng, F. Chen, M. Wen, F. Ji, H. Yu, and Y. Liu, "Low-complexity ML detector and performance analysis for OFDM with in-phase/quadrature index modulation," *IEEE Communications Letters*, vol. 19, no. 11, pp. 1893–1896, 2015.

- [96] A. Younis, N. Abuzgaia, R. Mesleh, and H. Haas, "Quadrature spatial modulation for 5G outdoor millimeter-wave communications: Capacity analysis," *IEEE Transactions on Wireless Communications*, vol. 16, no. 5, pp. 2882–2890, 2017.
- [97] S. Althunibat and R. Mesleh, "Performance analysis of quadrature spatial modulation in two-way relaying cooperative networks," *IET Communications*, vol. 12, no. 4, pp. 466–472, 2018.
- [98] I. A. Nahhal, O. A. Dobre, and S. S. Ikki, "Quadrature spatial modulation decoding complexity: study and reduction," *IEEE Wireless Letters*, vol. 6, no. 3, pp. 378–381, 2017.
- [99] B. Shamasundar, S. Jacob, and A. Chockalingam, "Time-indexed media-based modulation," in *2017 IEEE 85th Vehicular Technology Conference (VTC Spring)*. IEEE, 2017, pp. 1–5.
- [100] I. Al-Nahhal, O. A. Dobre, E. Basar, and S. Ikki, "Low-cost uplink sparse code multiple access for spatial modulation," *IEEE Transactions on Vehicular Technology*, vol. 68, no. 9, pp. 9313–9317, 2019.
- [101] X. Wang, J. Wang, L. He, Z. Tang, and J. Song, "On the achievable spectral efficiency of spatial modulation aided downlink non-orthogonal multiple access," *IEEE Communications Letters*, vol. 21, no. 9, pp. 1937–1940, 2017.
- [102] Q. Wang, Z. Wang, S. Chen, and L. Hanzo, "Enhancing the decoding performance of optical wireless communication systems using receiver-side predistortion," *Optics express*, vol. 21, no. 25, pp. 30295–30305, 2013.
- [103] L. Xiao, P. Yang, Y. Xiao, S. Fan, M. Di Renzo, W. Xiang, and S. Li, "Efficient compressive sensing detectors for generalized spatial modulation systems," *IEEE Transactions on Vehicular Technology*, vol. 66, no. 2, pp. 1284–1298, 2016.
- [104] B. Zong, C. Fan, X. Wang, X. Duan, B. Wang, and J. Wang, "6G technologies: Key drivers, core requirements, system architectures, and enabling technologies," *IEEE Vehicular Technology Magazine*, vol. 14, no. 3, pp. 18–27, 2019.
- [105] K. B. Letaief, W. Chen, Y. Shi, J. Zhang, and Y.-J. A. Zhang, "The roadmap to 6G: AI empowered wireless networks," *IEEE Communications Magazine*, vol. 57, no. 8, pp. 84–90, 2019.
- [106] M. Elsayed and M. Erol-Kantarci, "AI-Enabled future wireless networks: Challenges, opportunities, and open issues," *IEEE Vehicular Technology Magazine*, vol. 14, no. 3, pp. 70–77, 2019.
- [107] A. Zappone, M. Di Renzo, M. Debbah, T. T. Lam, and X. Qian, "Model-aided wireless artificial intelligence: Embedding expert knowledge in deep neural networks for wireless system optimization," *IEEE Vehicular Technology Magazine*, vol. 14, no. 3, pp. 60–69, 2019.
- [108] H. Gacanin, "Autonomous wireless systems with artificial intelligence: A knowledge management perspective," *IEEE Vehicular Technology Magazine*, vol. 14, no. 3, pp. 51–59, 2019.
- [109] R.-A. Stoica and G. T. F. de Abreu, "6G: the wireless communications network for collaborative and AI applications," *arXiv preprint arXiv:1904.03413*, 2019.
- [110] Z. Zhang, Y. Xiao, Z. Ma, M. Xiao, Z. Ding, X. Lei, G. K. Karagiannis, and P. Fan, "6G wireless networks: Vision, requirements, architecture, and key technologies," *IEEE Vehicular Technology Magazine*, vol. 14, no. 3, pp. 28–41, 2019.
- [111] L. Zhang, Y.-C. Liang, and D. Niyato, "6G visions: Mobile ultra-broadband, super Internet-of-Things, and artificial intelligence," *China Communications*, vol. 16, no. 8, pp. 1–14, 2019.
- [112] Q. Mao, F. Hu, and Q. Hao, "Deep learning for intelligent wireless networks: A comprehensive survey," *IEEE Communications Surveys & Tutorials*, vol. 20, no. 4, pp. 2595–2621, 2018.
- [113] F. Tang, Y. Kawamoto, N. Kato, and J. Liu, "Future intelligent and secure vehicular network toward 6G: Machine-learning approaches," *Proceedings of the IEEE*, vol. 108, no. 2, pp. 292–307, 2019.
- [114] Y. Xiao, G. Shi, Y. Li, W. Saad, and H. V. Poor, "Towards self-learning edge intelligence in 6G," *arXiv preprint arXiv:2010.00176*, 2020.
- [115] F. Jameel, N. Sharma, M. A. Khan, I. Khan, M. M. Alam, G. Mastrokakis, and C. X. Mavroumoustakis, "Machine learning techniques for wireless-powered ambient backscatter communications: Enabling intelligent IoT networks in 6G era," in *Convergence of Artificial Intelligence and the Internet of Things*. Springer, 2020, pp. 187–211.
- [116] Y. Sun, J. Liu, J. Wang, Y. Cao, and N. Kato, "When machine learning meets privacy in 6G: A survey," *IEEE Communications Surveys & Tutorials*, vol. 22, no. 4, pp. 2694–2724, 2020.
- [117] W. Guo, "Explainable artificial intelligence for 6G: Improving trust between human and machine," *IEEE Communications Magazine*, vol. 58, no. 6, pp. 39–45, 2020.
- [118] J. Du, C. Jiang, J. Wang, Y. Ren, and M. Debbah, "Machine learning for 6G wireless networks: Carrying forward enhanced bandwidth, massive access, and ultrareliable/low-latency service," *IEEE Vehicular Technology Magazine*, vol. 15, no. 4, pp. 122–134, 2020.
- [119] S. Han, T. Xie, I. Chih-Lin, L. Chai, Z. Liu, Y. Yuan, and C. Cui, "Artificial-Intelligence-Enabled air interface for 6G: Solutions, challenges, and standardization impacts," *IEEE Communications Magazine*, vol. 58, no. 10, pp. 73–79, 2020.
- [120] Y. Liu, S. Bi, Z. Shi, and L. Hanzo, "When machine learning meets big data: A wireless communication perspective," *IEEE Vehicular Technology Magazine*, vol. 15, no. 1, pp. 63–72, 2019.
- [121] R. W. Liu, J. Nie, S. Garg, Z. Xiong, Y. Zhang, and M. S. Hossain, "Data-driven trajectory quality improvement for promoting intelligent vessel traffic services in 6G-enabled maritime IoT systems," *IEEE Internet of Things Journal*, 2020.
- [122] H. Yang, A. Alphones, Z. Xiong, D. Niyato, J. Zhao, and K. Wu, "Artificial-intelligence-enabled intelligent 6G networks," *IEEE Network*, vol. 34, no. 6, pp. 272–280, 2020.
- [123] Z. Huang and X. Cheng, "A general 3d space-time-frequency non-stationary model for 6G channels," *IEEE Transactions on Wireless Communications*, 2020.
- [124] M. Giordani, M. Polese, M. Mezzavilla, S. Rangan, and M. Zorzi, "Toward 6G networks: Use cases and technologies," *IEEE Communications Magazine*, vol. 58, no. 3, pp. 55–61, 2020.
- [125] Y. Dai, D. Xu, S. Maharjan, Z. Chen, Q. He, and Y. Zhang, "Blockchain and deep reinforcement learning empowered intelligent 5G beyond," *IEEE Network*, vol. 33, no. 3, pp. 10–17, 2019.
- [126] F. Tang, Y. Zhou, and N. Kato, "Deep reinforcement learning for dynamic uplink/downlink resource allocation in high mobility 5G hetnet," *IEEE Journal on Selected Areas in Communications*, vol. 38, no. 12, pp. 2773–2782, 2020.
- [127] Z. Xiong, Y. Zhang, D. Niyato, R. Deng, P. Wang, and L.-C. Wang, "Deep reinforcement learning for mobile 5G and beyond: Fundamentals, applications, and challenges," *IEEE Vehicular Technology Magazine*, vol. 14, no. 2, pp. 44–52, 2019.
- [128] R. Zhao, X. Wang, J. Xia, and L. Fan, "Deep reinforcement learning based mobile edge computing for intelligent internet of things," *Physical Communication*, vol. 43, p. 101184, 2020.
- [129] Y. Al-Eryani, M. Akrouf, and E. Hossain, "Multiple access in cell-free networks: Outage performance, dynamic clustering, and deep reinforcement learning-based design," *IEEE Journal on Selected Areas in Communications*, 2020.
- [130] H. He, R. Wang, S. Jin, C.-K. Wen, and G. Y. Li, "Beamspace channel estimation in terahertz communications: A model-driven unsupervised learning approach," *arXiv preprint arXiv:2006.16628*, 2020.
- [131] C. Huang, R. Mo, C. Yuen *et al.*, "Reconfigurable intelligent surface assisted multiuser MISO systems exploiting deep reinforcement learning," *arXiv preprint arXiv:2002.10072*, 2020.
- [132] Y. Zhang, Z. Mou, F. Gao, J. Jiang, R. Ding, and Z. Han, "UAV-enabled secure communications by multi-agent deep reinforcement learning," *IEEE Transactions on Vehicular Technology*, vol. 69, no. 10, pp. 11599–11611, 2020.
- [133] S. P. Rout, "6g wireless communication: Its vision, viability, application, requirement, technologies, encounters and research," in *2020 11th International Conference on Computing, Communication and Networking Technologies (ICCCNT)*. IEEE, 2020, pp. 1–8.
- [134] J. Du, F. R. Yu, G. Lu, J. Wang, J. Jiang, and X. Chu, "MEC-assisted immersive VR video streaming over terahertz wireless networks: A deep reinforcement learning approach," *IEEE Internet of Things Journal*, vol. 7, no. 10, pp. 9517–9529, 2020.
- [135] L. Wang, K. Wang, C. Pan, W. Xu, N. Aslam, and L. Hanzo, "Multi-agent deep reinforcement learning based trajectory planning for multi-UAV assisted mobile edge computing," *IEEE Transactions on Cognitive Communications and Networking*, 2020.
- [136] Y. Lu, X. Huang, K. Zhang, S. Maharjan, and Y. Zhang, "Low-latency federated learning and blockchain for edge association in digital twin empowered 6G networks," *IEEE Transactions on Industrial Informatics*, 2020.
- [137] M. Aledhari, R. Razzak, R. M. Parizi, and F. Saeed, "Federated learning: A survey on enabling technologies, protocols, and applications," *IEEE Access*, vol. 8, pp. 140699–140725, 2020.
- [138] K. Yang, T. Jiang, Y. Shi, and Z. Ding, "Federated learning via over-the-air computation," *IEEE Transactions on Wireless Communications*, vol. 19, no. 3, pp. 2022–2035, 2020.
- [139] L. U. Khan, W. Saad, Z. Han, E. Hossain, and C. S. Hong, "Federated learning for internet of things: Recent advances, taxonomy, and open challenges," *arXiv preprint arXiv:2009.13012*, 2020.
- [140] M. Chen, Z. Yang, W. Saad, C. Yin, H. V. Poor, and S. Cui, "A joint learning and communications framework for federated learning over

- wireless networks," *IEEE Transactions on Wireless Communications*, 2020.
- [141] L. U. Khan, I. Yaqoob, M. Imran, Z. Han, and C. S. Hong, "6G wireless systems: A vision, architectural elements, and future directions," *IEEE Access*, vol. 8, pp. 147 029–147 044, 2020.
- [142] Y. Qu, C. Dong, J. Zheng, Q. Wu, Y. Shen, F. Wu, and A. Anpalagan, "Empowering the edge intelligence by air-ground integrated federated learning in 6G networks," *arXiv preprint arXiv:2007.13054*, 2020.
- [143] Z. M. Fadlullah and N. Kato, "HCP: heterogeneous computing platform for federated learning based collaborative content caching towards 6G networks," *IEEE Transactions on Emerging Topics in Computing*, 2020.
- [144] Z. Zhao, C. Feng, H. H. Yang, and X. Luo, "Federated-learning-enabled intelligent fog radio access networks: Fundamental theory, key techniques, and future trends," *IEEE Wireless Communications*, vol. 27, no. 2, pp. 22–28, 2020.
- [145] Z. Yang, M. Chen, W. Saad, C. S. Hong, and M. Shikh-Bahaei, "Energy efficient federated learning over wireless communication networks," *IEEE Transactions on Wireless Communications*, 2020.
- [146] H. He, S. Jin, C.-K. Wen, F. Gao, G. Y. Li, and Z. Xu, "Model-driven deep learning for physical layer communications," *IEEE Wireless Communications*, 2019.
- [147] J. Konečný, H. B. McMahan, F. X. Yu, P. Richtárik, A. T. Suresh, and D. Bacon, "Federated learning: Strategies for improving communication efficiency," *arXiv preprint arXiv:1610.05492*, 2016.
- [148] R. Shafin, L. Liu, V. Chandrasekhar, H. Chen, J. Reed, and J. Zhang, "Artificial intelligence-enabled cellular networks: A critical path to beyond-5G and 6G," *arXiv preprint arXiv:1907.07862*, 2019.
- [149] T. Cousik, R. Shafin, Z. Zhou, K. Kleine, J. Reed, and L. Liu, "CogRF: A new frontier for machine learning and artificial intelligence for 6G RF systems," *arXiv preprint arXiv:1909.06862*, 2019.
- [150] W. Guo, "Explainable artificial intelligence (XAI) for 6G: Improving trust between human and machine," *arXiv preprint arXiv:1911.04542*, 2019.
- [151] A. Faisal, H. Sameddeen, H. Dahrouj, T. Y. Al-Naffouri, and M.-S. Alouini, "Ultra-massive MIMO systems at terahertz bands: Prospects and challenges," *arXiv preprint arXiv:1902.11090*, 2019.
- [152] S. Hu, F. Rusek, and O. Edfors, "Beyond massive MIMO: The potential of data transmission with large intelligent surfaces," *IEEE Transactions on Signal Processing*, vol. 66, no. 10, pp. 2746–2758, 2018.
- [153] M. Di Renzo, M. Debbah, D.-T. Phan-Huy, A. Zappone, M.-S. Alouini, C. Yuen, V. Sciancalepore, G. C. Alexandropoulos, J. Hoydis, H. Gacanin, J. d. Rosny, A. Bounceur, G. Lerosey, and M. Fink, "Smart radio environments empowered by reconfigurable AI metasurfaces: An idea whose time has come," *EURASIP Journal on Wireless Communications and Networking*, vol. 2019, no. 1, pp. 1–20, 2019.
- [154] S. Hu, F. Rusek, and O. Edfors, "The potential of using large antenna arrays on intelligent surfaces," in *2017 IEEE 85th Vehicular Technology Conference (VTC Spring)*. IEEE, 2017, pp. 1–6.
- [155] Q.-U.-A. Nadeem, A. Kammoun, A. Chaaban, M. Debbah, and M.-S. Alouini, "Large intelligent surface assisted MIMO communications," *arXiv preprint arXiv:1903.08127*, 2019.
- [156] M. Jung, W. Saad, and G. Kong, "Performance analysis of large intelligent surfaces (liss): Uplink spectral efficiency and pilot training," *arXiv preprint arXiv:1904.00453*, 2019.
- [157] E. De Carvalho, A. Ali, A. Amiri, M. Angjelichinoski, and R. W. Heath Jr, "Non-stationarities in extra-large scale massive MIMO," *arXiv preprint arXiv:1903.03085*, 2019.
- [158] S. Hu, K. Chitti, F. Rusek, and O. Edfors, "User assignment with distributed large intelligent surface (LIS) systems," in *2018 IEEE 29th Annual International Symposium on Personal, Indoor and Mobile Radio Communications (PIMRC)*. IEEE, 2018, pp. 1–6.
- [159] S. Hu, F. Rusek, and O. Edfors, "Cramér-rao lower bounds for positioning with large intelligent surfaces," in *2017 IEEE 86th Vehicular Technology Conference (VTC-Fall)*. IEEE, 2017, pp. 1–6.
- [160] S. Gong, X. Lu, D. T. Hoang, D. Niyato, L. Shu, D. I. Kim, and Y.-C. Liang, "Towards smart radio environment for wireless communications via intelligent reflecting surfaces: A comprehensive survey," *arXiv preprint arXiv:1912.07794*, 2019.
- [161] E. Basar, M. Di Renzo, J. De Rosny, M. Debbah, M.-S. Alouini, and R. Zhang, "Wireless communications through reconfigurable intelligent surfaces," *IEEE Access*, vol. 7, pp. 116 753–116 773, 2019.
- [162] Ö. Özdogan, E. Björnson, and E. G. Larsson, "Intelligent reflecting surfaces: Physics, propagation, and pathloss modeling," *IEEE Wireless Communications Letters*, vol. 9, no. 5, pp. 581–585, 2019.
- [163] Y.-C. Liang, R. Long, Q. Zhang, J. Chen, H. V. Cheng, and H. Guo, "Large intelligent surface/antennas (LISA): Making reflective radios smart," *Journal of Communications and Information Networks*, vol. 4, no. 2, pp. 40–50, 2019.
- [164] C. Liaskos, S. Nie, A. Tsioliaridou, A. Pitsillides, S. Ioannidis, and I. Akyildiz, "A new wireless communication paradigm through software-controlled metasurfaces," *IEEE Communications Magazine*, vol. 56, no. 9, pp. 162–169, 2018.
- [165] Q. Wu and R. Zhang, "Towards smart and reconfigurable environment: Intelligent reflecting surface aided wireless network," *IEEE Communications Magazine*, vol. 58, no. 1, pp. 106–112, 2019.
- [166] A. L. Yuille and A. Rangarajan, "The concave-convex procedure," *Neural Computation*, vol. 15, no. 4, pp. 915–936, 2003.
- [167] T. Lipp and S. Boyd, "Variations and extension of the convex-concave procedure," *Optimization and Engineering*, vol. 17, no. 2, pp. 263–287, 2016.
- [168] S. Boyd and L. Vandenberghe, "Convex optimization," *Cabridge University Press*, 2014.
- [169] H. Han, J. Zhao, D. Niyato, M. Di Renzo, and Q.-V. Pham, "Intelligent reflecting surface aided network: Power control for physical-layer broadcasting," in *ICC 2020-2020 IEEE International Conference on Communications (ICC)*. IEEE, 2020, pp. 1–7.
- [170] Q. Wu and R. Zhang, "Joint active and passive beamforming optimization for intelligent reflecting surface assisted SWIPT under QoS constraints," *IEEE Journal on Selected Areas in Communications*, vol. 38, no. 8, pp. 1735–1748, 2020.
- [171] X. Tan, Z. Sun, and J. M. Jornet, "Increasing indoor spectrum sharing capacity using smart reflect-array," in *2016 IEEE International Conference on Communications (ICC)*. IEEE, 2016, pp. 1–6.
- [172] X. Tan, Z. Sun, and D. Koutsoni, "Enabling indoor mobile millimeter-wave networks based on smart reflect-arrays," in *2018 IEEE 29th Annual International Symposium on Personal, Indoor and Mobile Radio Communications (PIMRC)*. IEEE, 2018, pp. 1–6.
- [173] S. Nie, J. M. Jornet, and I. F. Akyildiz, "Intelligent environments based on ultra-massive MIMO platforms for wireless communication in millimeter wave and terahertz bands," in *2019 IEEE International Conference on Acoustics, Speech and Signal Processing (ICASSP)*. IEEE, 2019, pp. 7849–7853.
- [174] Y. Yang, S. Zhang, and R. Zhang, "Irs-enhanced OFDM: Power allocation and passive array optimization," in *2019 IEEE Global Communications Conference (GLOBECOM)*. IEEE, 2019, pp. 1–6.
- [175] S. Hu, F. Rusek, and O. Edfors, "Capacity degradation with modeling hardware impairment in large intelligent surface," in *2018 IEEE Global Communications Conference (GLOBECOM)*. IEEE, 2018, pp. 1–6.
- [176] E. Basar, "Reconfigurable intelligent surface-based index modulation: A new beyond MIMO paradigm for 6G," *IEEE Transactions on Communications*, vol. 68, no. 5, pp. 3187–3196, 2020.
- [177] Q. U. A. Nadeem, H. Alwazani, and A. Kammoun, "Intelligent reflecting surface assisted multi-user MISO communication: channel estimation and beamforming design," *IEEE Open Journal of the Communications Society*, vol. 1, pp. 661–680, 2020.
- [178] Z. He and X. Yuan, "Cascaded channel estimation for large intelligent metasurface assisted massive MIMO," *IEEE Wireless Communication Letters*, vol. 9, no. 2, pp. 6210–6214, 2020.
- [179] B. Zheng and R. Zhang, "Intelligent reflecting surface-enhanced OFDM: Channel estimation and reflection optimization," *IEEE Wireless Communications Letters*, vol. 9, no. 4, pp. 518–522, 2019.
- [180] B. Di, H. Zhang, L. Song, Y. Li, Z. Han, and H. V. Poor, "Hybrid beamforming for reconfigurable intelligent surface based multi-user communications: Achievable rates with limited discrete phase shifts," *IEEE Journal on Selected Areas in Communications*, vol. 38, no. 8, pp. 1809–1822, 2020.
- [181] D. M. Pozar, *Microwave engineering*. John wiley & sons, 2011.
- [182] S. Koziel, "Surrogate-based modeling and optimization: applications in engineering," *New York, NY: Springer*, 2013.
- [183] D. R. Smith, O. Yurduseven, L. P. Mancera, P. Bowen, and N. B. Kundtz, "Analysis of a waveguide-fed metasurface antenna," *Physical Review Applied*, vol. 8, no. 5, p. 054048, 2017.
- [184] S. Abeywickrama, R. Zhang, Q. Wu, and C. Yuen, "Intelligent reflecting surface: practical phase shift model and beamforming optimization," in *2020 IEEE International Conference on Communications (ICC)*. IEEE, 2020, pp. 1–6.
- [185] —, "Intelligent reflecting surface: practical phase shift model and beamforming optimization," *IEEE Transactions on Communications*, vol. 68, no. 9, pp. 5849–5863, 2020.
- [186] Z.-Q. He and X. Yuan, "Cascaded channel estimation for large intelligent metasurface assisted massive MIMO," *IEEE Wireless Communications Letters*, vol. 9, no. 2, pp. 210–214, 2019.

- [187] C. Liaskos, A. Tsioliaridou, and S. Nie, "An interpretable neural network for configuring pro-grammable wireless environments," in *2019 IEEE 20th International Workshop on Signal Processing Advances in Wireless Communications (SPAWC)*. IEEE, 2019, pp. 1–6.
- [188] Y. Yuan, Y. Zhao, B. Zong, and S. Parolari, "Potential key technologies for 6G mobile communications," *Science China Information Sciences*, vol. 63, pp. 1–19, 2020.
- [189] C. Huang, S. Hu, G. C. Alexandropoulos, A. Zappone, C. Yuen, R. Zhang, M. Di Renzo, and M. Debbah, "Holographic MIMO surfaces for 6G wireless networks: Opportunities, challenges, and trends," *IEEE Wireless Communications*, vol. 27, no. 5, pp. 118–125, 2020.
- [190] R. J. Williams, E. De Carvalho, and T. L. Marzetta, "A communication model for large intelligent surfaces," in *2020 IEEE International Conference on Communications Workshops (ICC Workshops)*. IEEE, 2020, pp. 1–6.
- [191] X. Meng, F. Liu, J. Zhou, and S. Yang, "Interference exploitation precoding for intelligent reflecting surface aided communication system," *IEEE Wireless Communications Letters*, 2020.
- [192] Q. Gu, G. Wang, and R. Fan, "Rate-energy tradeoff in simultaneous wireless information and power transfer over fading channels with uncertain distribution," *IEEE Transactions on Vehicular Technology*, vol. 67, no. 4, pp. 3663–3668, 2018.
- [193] G. Pan, H. Lei, and Y. Yuan, "Performance analysis and optimization for SWIPT wireless sensor networks," *IEEE Transactions on Communications*, vol. 65, no. 5, pp. 2291–2302, 2017.
- [194] L. R. Varshney, "Transporting information and energy simultaneously," in *2008 IEEE International Symposium on Information Theory (ISIT)*. IEEE, 2008, pp. 1612–1616.
- [195] X. Zhou, R. Zhang, and C. K. Ho, "Wireless information and power transfer: architecture design and rate-energy tradeoff," *IEEE Transactions on Communications*, vol. 61, no. 11, pp. 4754–4767, 2013.
- [196] M. Babaei, U. Ayyolu, and E. Basar, "Ber analysis of dual-hop relaying with energy harvesting in Nakagami-m fading channel," *IEEE Transactions on Communications*, vol. 17, no. 7, pp. 4352–4361, 2018.
- [197] T. D. P. Perera, D. N. K. Jayakody, S. K. Sharma, S. Chatzinotas, and J. Li, "Simultaneous wireless information and power transfer (swipt): Recent advances and future challenges," *IEEE Communications Surveys & Tutorials*, vol. 20, no. 1, pp. 264–302, 2017.
- [198] R. Zhang, "MIMO broadcasting for simultaneous wireless information and power transfer," *IEEE Transactions on Communications*, vol. 17, no. 7, pp. 4352–4361, 2018.
- [199] M. Del Prete, F. Berra, A. Costanzo, and D. Masotti, "Exploitation of a dual-band cell phone antenna for near-field WPT," in *2015 IEEE Wireless Power Transfer Conference (WPTC)*. IEEE, 2015, pp. 1–4.
- [200] Y. Zhang, J. Ge, and E. Serpedin, "Performance analysis of a 5G energy constrained downlink relaying network with non-orthogonal multiple access," *IEEE Transactions on Communications*, vol. 16, no. 12, pp. 8333–8346, 2017.
- [201] Z. Yang, Z. Ding, P. Fan, and N. Al-Dhahir, "The impact of power allocation on cooperative non-orthogonal multiple access networks with SWIPT," *IEEE Transactions on Wireless Communications*, vol. 16, no. 7, pp. 4332–4343, 2017.
- [202] J. Gong and X. Chen, "Achievable rate region of non-orthogonal multiple access systems with wireless powered decoder," *IEEE Journal on Selected Areas in Communications*, vol. 35, no. 12, pp. 2846–2859, 2017.
- [203] Y. Alsaba, C. Y. Leow, and S. K. A. Rahim, "Full-duplex cooperative non-orthogonal multiple access with beamforming and energy harvesting," *IEEE Access*, vol. 6, pp. 19 726–79 738, 2018.
- [204] L. Bariah, S. Muhaidat, and A. A. Dweik, "Error probability analysis of NOMA-based relay networks with SWIPT," *IEEE Communications Letters*, vol. 23, no. 7, pp. 1223–1226, 2019.
- [205] M. Hedayati and I. Kim, "On the performance of noma in the two-user SWIPT system," *IEEE Transactions Vehicular Technology*, vol. 67, no. 11, pp. 11 258–11 263, 2018.
- [206] S. Li, L. Bariah, S. Muhaidat, P. Sofotasios, J. Liang, and A. Wang, "Error analysis of noma-based user cooperation with SWIPT," in *2019 15th International Conference on Distributed Computing in Sensor Systems (DCOSS)*. IEEE, 2019, pp. 507–513.
- [207] H. K. Sahu and P. R. Sahu, "Ssk-based SWIPT with AF relay," *IEEE Communications Letters*, vol. 23, no. 4, pp. 756–759, 2019.
- [208] X. Jin, L. Yang, N. Jin, and D. Chen, "Performance analysis of a wireless energy-harvesting cooperative system with precoding spatial modulation," *IET Communications*, vol. 13, no. 15, pp. 2369–2374, 2019.
- [209] Y. Kawamoto, H. Nishiyama, N. Kato, and N. Kadowaki, "A traffic distribution technique to minimize packet delivery delay in multilayered satellite networks," *IEEE Transactions on Vehicular Technology*, vol. 62, no. 7, pp. 3315–3324, 2013.
- [210] R. Radhakrishnan, W. W. Edmonson, F. Afghah, R. M. Rodriguez-Osorio, F. Pinto, and S. C. Burleigh, "Survey of inter-satellite communication for small satellite systems: Physical layer to network layer view," *IEEE Communications Surveys & Tutorials*, vol. 18, no. 4, pp. 2442–2473, 2016.
- [211] C. Niephaus, M. Kretschmer, and G. Ghinea, "QoS provisioning in converged satellite and terrestrial networks: A survey of the state-of-the-art," *IEEE Communications Surveys & Tutorials*, vol. 18, no. 4, pp. 2415–2441, 2016.
- [212] M. Hamdi, N. Boudriga, and M. S. Obaidat, "Bandwidth-effective design of a satellite-based hybrid wireless sensor network for mobile target detection and tracking," *IEEE Systems Journal*, vol. 2, no. 1, pp. 74–82, 2008.
- [213] P. Chini, G. Giambene, and S. Kota, "A survey on mobile satellite systems," *Int. J. Satellite Communications Networking*, vol. 28, pp. 29–57, 01 2009.
- [214] Y. Zhao, G. Yu, and H. Xu, "6G mobile communication network: vision, challenges and key technologies," *arXiv preprint arXiv:1905.04983*, 2019.
- [215] W. Y. B. Lim, J. Huang, Z. Xiong, J. Kang, D. Niyato, X.-S. Hua, C. Leung, and C. Miao, "Towards federated learning in UAV-enabled Internet of Vehicles: A multi-dimensional contract-matching approach," *arXiv preprint arXiv:2004.03877*, 2020.
- [216] T. Zeng, O. Semiari, M. Mozaffari, M. Chen, W. Saad, and M. Bennis, "Federated learning in the sky: Joint power allocation and scheduling with UAV swarms," *arXiv preprint arXiv:2002.08196*, 2020.
- [217] J. Zhang, M. M. Wang, T. Xia, and L. Wang, "Maritime IoT: An architectural and radio spectrum perspective," *IEEE Access*, vol. 8, pp. 93 109–93 122, 2020.
- [218] T. Xia, M. M. Wang, J. Zhang, and L. Wang, "Maritime Internet of Things: Challenges and solutions," *IEEE Wireless Communications*, vol. 27, no. 2, pp. 188–196, 2020.
- [219] L. Gupta, R. Jain, and G. Vaszkun, "Survey of important issues in UAV communication networks," *IEEE Communications Surveys & Tutorials*, vol. 18, no. 2, pp. 1123–1152, 2015.
- [220] S. Zhang, J. Liu, H. Guo, M. Qi, and N. Kato, "Envisioning device-to-device communications in 6G," *IEEE Network*, vol. 34, no. 3, pp. 86–91, 2020.
- [221] Y. Chen, B. Ai, H. Zhang, Y. Niu, L. Song, Z. Han, and H. V. Poor, "Reconfigurable intelligent surface assisted device-to-device communications," *arXiv preprint arXiv:2007.00859*, 2020.
- [222] M. Amjad, F. Akhtar, M. H. Rehmani, M. Reisslein, and T. Umer, "Full-duplex communication in cognitive radio networks: A survey," *IEEE Communications Surveys & Tutorials*, vol. 19, no. 4, pp. 2158–2191, 2017.
- [223] Z. Yuan, Y. Ma, Y. Hu, and W. Li, "High-efficiency full-duplex V2V communication," in *2020 2nd 6G Wireless Summit (6G SUMMIT)*. IEEE, 2020, pp. 1–5.
- [224] D. Xu, X. Yu, Y. Sun, D. W. K. Ng, and R. Schober, "Resource allocation for IRS-assisted full-duplex cognitive radio systems," *arXiv preprint arXiv:2003.07467*, 2020.
- [225] H. Shen, T. Ding, W. Xu, and C. Zhao, "Beamforming design with fast convergence for IRS-Aided full-duplex communication," *IEEE Communications Letters*, 2020.
- [226] G. Pan, J. Ye, J. An, and M.-S. Alouini, "When Full-Duplex transmission meets intelligent reflecting surface: Opportunities and challenges," *arXiv preprint arXiv:2005.12561*, 2020.
- [227] H. Yang and T. L. Marzetta, "A macro cellular wireless network with uniformly high user throughputs," in *2014 IEEE 80th Vehicular Technology Conference (VTC2014-Fall)*. IEEE, 2014, pp. 1–5.
- [228] T. T. Vu, D. T. Ngo, N. H. Tran, H. Q. Ngo, M. N. Dao, and R. H. Middleton, "Cell-free massive MIMO for wireless federated learning," *IEEE Transactions on Wireless Communications*, vol. 19, no. 10, pp. 6377–6392, 2020.
- [229] M. Bashar, A. Akbari, K. Cumanan, H. Quoc Ngo, A. G. Burr, P. Xiao, and M. Debbah, "Deep learning-aided finite-capacity fronthaul cell-free massive MIMO with zero forcing," *IEEE ICC 2020*, 2020.
- [230] G. Wood, "Ethereum: A secure decentralised generalised transaction ledger," *Ethereum project yellow paper*, vol. 151, no. 2014, pp. 1–32, 2014.
- [231] M. B. Mollah, J. Zhao, D. Niyato, K.-Y. Lam, X. Zhang, A. M. Ghias, L. H. Koh, and L. Yang, "Blockchain for future smart grid: A comprehensive survey," *IEEE Internet of Things Journal*, 2020.

- [232] P. Porambage, T. Kumar, M. Liyanage, J. Partala, L. Lovén, M. Ylianttila, and T. Seppänen, “Sec-EdgeAI: AI for edge security vs security for edge AI.”
- [233] X. Ling, J. Wang, T. Bouchoucha, B. C. Levy, and Z. Ding, “Blockchain radio access network (B-RAN): Towards decentralized secure radio access paradigm,” *IEEE Access*, vol. 7, pp. 9714–9723, 2019.
- [234] Y. Le, X. Ling, J. Wang, and Z. Ding, “Prototype design and test of blockchain radio access network,” in *2019 IEEE International Conference on Communications Workshops (ICC Workshops)*. IEEE, 2019, pp. 1–6.
- [235] H. Sameddeen, N. Saeed, T. Y. Al-Naffouri, and M.-S. Alouini, “Next generation terahertz communications: A rendezvous of sensing, imaging, and localization,” *IEEE Communications Magazine*, vol. 58, no. 5, pp. 69–75, 2020.
- [236] P. Chevalier, A. Armizhan, F. Wang, M. Piccardo, S. G. Johnson, F. Capasso, and H. O. Everitt, “Widely tunable compact terahertz gas lasers,” *Science*, vol. 366, no. 6467, pp. 856–860, 2019.
- [237] C. Han, Y. Wu, Z. Chen, and X. Wang, “Terahertz communications (teracom): Challenges and impact on 6G wireless systems,” *arXiv preprint arXiv:1912.06040*, 2019.
- [238] C. Han and Y. Chen, “Propagation modeling for wireless communications in the terahertz band,” *IEEE Communications Magazine*, vol. 56, no. 6, pp. 96–101, 2018.
- [239] N. Khalid and O. B. Akan, “Wideband THz communication channel measurements for 5G indoor wireless networks,” in *2016 IEEE International Conference on Communications (ICC)*. IEEE, 2016, pp. 1–6.
- [240] S. Ariyanti and M. Suryanegara, “Visible light communication (vlc) for 6G technology: The potency and research challenges,” in *2020 Fourth World Conference on Smart Trends in Systems, Security and Sustainability (WorldS4)*. IEEE, 2020, pp. 490–493.
- [241] M. A. Arfaoui, M. D. Soltani, I. Tavakkolnia, A. Ghrayeb, M. Safari, C. Assi, and H. Haas, “Physical layer security for visible light communication systems: A survey,” *IEEE Communications Surveys & Tutorials*, 2020.
- [242] “6G white paper.” <http://jultika.oulu.fi/Record/isbn978-952-62-2354-4>.
- [243] M. Z. Chowdhury, M. Shahjalal, M. Hasan, and Y. M. Jang, “The role of optical wireless communication technologies in 5G/6G and IoT solutions: Prospects, directions, and challenges,” *Applied Sciences*, vol. 9, no. 20, p. 4367, 2019.
- [244] M. Katz and I. Ahmed, “Opportunities and challenges for visible light communications in 6G,” in *2020 2nd 6G Wireless Summit (6G SUMMIT)*. IEEE, 2020, pp. 1–5.
- [245] H. Shen, W. Xu, S. Gong, Z. He, and C. Zhao, “Secrecy rate maximization for intelligent reflecting surface assisted multi-antenna communications,” *IEEE Communications Letters*, vol. 23, no. 9, pp. 1488–1492, 2019.
- [246] S. Hong, C. Pan, H. Ren, K. Wang, and A. Nallanathan, “Artificial-noise-aided secure MIMO wireless communications via intelligent reflecting surface,” *arXiv preprint arXiv:2002.07063*, 2020.
- [247] X. Yu, D. Xu, Y. Sun, D. W. K. Ng, and R. Schober, “Robust and secure wireless communications via intelligent reflecting surfaces,” *IEEE Journal on Selected Areas in Communications*, 2020.
- [248] A. D. Wyner, “The wire-tap channel,” *Bell system technical journal*, vol. 54, no. 8, pp. 1355–1387, 1975.
- [249] I. Csiszár and J. Körner, “Broadcast channels with confidential messages,” *IEEE transactions on information theory*, vol. 24, no. 3, pp. 339–348, 1978.
- [250] H. Yamamoto, “A coding theorem for secret sharing communication systems with two THz wiretap channels,” *IEEE Transactions on Information Theory*, vol. 37, no. 3, pp. 634–638, 1991.
- [251] S. Leung-Yan-Cheong and M. Hellman, “The Gaussian wire-tap channel,” *IEEE transactions on information theory*, vol. 24, no. 4, pp. 451–456, 1978.
- [252] D. Klinc, J. Ha, S. W. McLaughlin, J. Barros, and B.-J. Kwak, “LDPC codes for the Gaussian wiretap channel,” *IEEE Transactions on Information Forensics and Security*, vol. 6, no. 3, pp. 532–540, 2011.
- [253] C. Sperandio and P. G. Flikkema, “Wireless physical-layer security via transmit precoding over dispersive channels: optimum linear eavesdropping,” in *MILCOM 2002. Proceedings*, vol. 2. IEEE, 2002, pp. 1113–1117.
- [254] W. E. Cobb, E. D. Laspe, R. O. Baldwin, M. A. Temple, and Y. C. Kim, “Intrinsic physical-layer authentication of integrated circuits,” *IEEE Transactions on Information Forensics and Security*, vol. 7, no. 1, pp. 14–24, 2011.
- [255] D. Shan, K. Zeng, W. Xiang, P. Richardson, and Y. Dong, “PHY-CRAM: Physical layer challenge-response authentication mechanism for wireless networks,” *IEEE Journal on selected areas in communications*, vol. 31, no. 9, pp. 1817–1827, 2013.
- [256] S. Goel and R. Negi, “Guaranteeing secrecy using artificial noise,” *IEEE transactions on wireless communications*, vol. 7, no. 6, pp. 2180–2189, 2008.
- [257] G. Fortino and P. Trunfio, *Internet of Things Based on Smart Objects, Technology, Middleware and Applications*, 01 2014.
- [258] A. Poniszewska-Maranda and D. Kaczmarek, “Selected methods of artificial intelligence for Internet of Things conception,” 10 2015, pp. 1343–1348.
- [259] M. B. Mollah, M. A. K. Azad, and A. Vasilakos, “Secure data sharing and searching at the edge of cloud-assisted Internet of Things,” *IEEE Cloud Computing*, vol. 4, no. 1, pp. 34–42, 2017.
- [260] T. Hewa, G. Gür, A. Kalla, M. Ylianttila, A. Braeken, and M. Liyanage, “The role of blockchain in 6G: Challenges, opportunities and research directions,” 03 2020.
- [261] G. Berardinelli, N. Mahmood, I. Rodriguez Larrad, and P. Mogensen, “Beyond 5G wireless irt for industry 4.0: Design principles and spectrum aspects,” 12 2018, pp. 1–6.
- [262] R. Sekaran, R. Patan, A. Raveendran, F. Al-Turjman, R. MANIKANDAN, and L. Mostarda, “Survival study on blockchain based 6G-enabled mobile edge computation for IoT automation,” *IEEE Access*, vol. PP, 08 2020.
- [263] E. Peltonen, M. Bennis, M. Capobianco, M. Debbah, A. Ding, F. Gil-Castiñeira, M. Jurmu, T. Karvonen, M. Kelanti, A. Kliks, T. Leppänen, L. Lovén, T. Mikkonen, A. Rao, S. Samarakoon, K. Seppänen, P. Sroka, S. Tarkoma, and T. Yang, “6G white paper on edge intelligence,” *arXiv preprint arXiv:2004.14850*, 2020.
- [264] N. Noury, A. Fleury, P. Rumeau, A. Bourke, G. ÓLaighin, V. Rialle, and J.-E. Lundy, “Fall detection – principles and methods,” *Annual International Conference of the IEEE Engineering in Medicine and Biology Society*, vol. 2007, pp. 1663–6, 02 2007.
- [265] B. Mao, Y. Kawamoto, and N. Kato, “AI-based joint optimization of QoS and security for 6G energy harvesting Internet of Things,” *IEEE Internet of Things Journal*, vol. PP, pp. 7032–7042, 03 2020.
- [266] G. Zheng, X. Zang, N. Xu, H. Wei, Z. Yu, V. Gayah, K. Xu, and Z. Li, “Diagnosing reinforcement learning for traffic signal control,” *arXiv preprint arXiv:1905.04716*, 2019.
- [267] Y. Sun, J. Liu, J. Wang, Y. Cao, and N. Kato, “When machine learning meets privacy in 6G: A survey,” *IEEE Communications Surveys & Tutorials*, vol. PP, 07 2020.
- [268] T. Zhang and Q. Zhu, “Distributed privacy-preserving collaborative intrusion detection systems for VANETs,” *IEEE Transactions on Signal and Information Processing over Networks*, vol. PP, 02 2018.
- [269] O. Dizdar, Y. Mao, W. Han, and B. Clerckx, “Rate-Splitting multiple access: A new frontier for the PHY layer of 6G,” *arxiv*, 06 2020.
- [270] P. Mehta, R. Gupta, and S. Tanwar, “Blockchain envisioned UAV networks: Challenges, solutions, and comparisons,” *Computer Communications*, vol. 151, 02 2020.
- [271] L. Mucchi, S. Jayousi, S. Caputo, E. Paoletti, P. Zoppi, S. Geli, and P. Dioniso, “How 6G technology can change the future wireless healthcare,” 03 2020, pp. 1–6.
- [272] A. Aygun, H. Ghasemzadeh, and R. Jafari, “Robust interbeat interval and heart rate variability estimation method from various morphological features using wearable sensors,” *IEEE Journal of Biomedical and Health Informatics*, vol. PP, 12 2019.
- [273] S. Tian, W. Yang, J. M. Le Grange, P. Wang, W. Huang, and Z. Ye, “Smart healthcare: making medical care more intelligent,” *Global Health Journal*, vol. 3, 10 2019.
- [274] G. Torfs, H. Li, S. Agneessens, J. Bauwelinck, L. Breyne, O. Caytan, W. Joseph, S. Lemey, H. Rogier, A. Thielens, D. V. Ginste, X. Yin, and P. Demeester, “ATTO: Wireless networking at fiber speed,” *Journal of Lightwave Technology*, vol. 36, no. 8, pp. 1468–1477, 2017.
- [275] J. Monserrat, D. Martin-Sacristan, F. Bouchmal, O. Carrasco, J. Flores de Valgas, and N. Cardona, “Key technologies for the advent of the 6G,” 04 2020, pp. 1–6.
- [276] I. Akyildiz, A. Kak, and S. Nie, “6G and beyond: The future of wireless communications systems,” *IEEE Access*, vol. PP, 07 2020.
- [277] N. Bizon, L. Dascalescu, and N. M. Tabatabaei, *Autonomous vehicles: Intelligent transport systems and smart technologies*, 01 2014.
- [278] J. Zhang, T. Chen, S. Zhong, J. Wang, W. Zhang, X. Zuo, R. Maunder, and L. Hanzo, “Aeronautical Ad Hoc networking for the Internet-Above-The-Clouds,” *Proceedings of the IEEE*, 05 2019.