



Blockchain Quick Facts For Business

A series of one-page fact sheets—everything from Blockchain 101 to the definition of interoperability. These are simple overviews developed by R3 to provide market participants with a basic understanding of what blockchain is, how it works, the Corda platform and its key differentiators.



Contents

What is a blockchain?	1
What is an enterprise blockchain?	2
Who is R3?	3
What is Corda?	4
How involved are regulators?.....	5
Data privacy.....	6
What is consensus?	7
What does decentralization mean?	8
What is interoperability?.....	9
Who is using Corda? What are some of the applications?.....	10
How does Corda compare to Fabric and Quorum?.....	11
What is Corda Settler?.....	12



What is a blockchain?

Blockchains are data structures where entries, usually transactions, are written to a database in bundles called blocks.

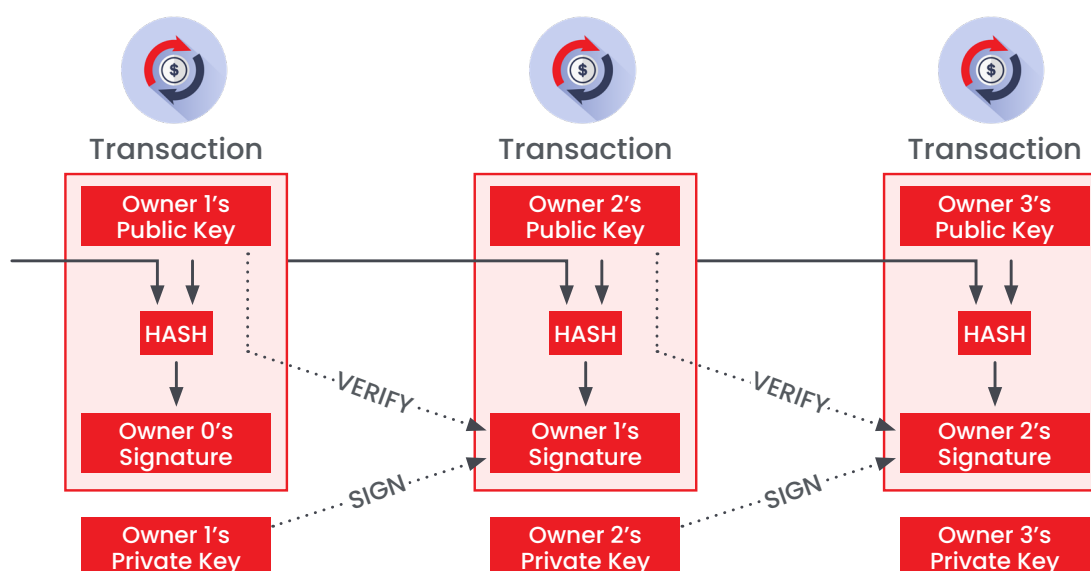

Each block refers to a previous block by a unique identifier known as its hash, which is determined by its contents. This forms a chain of blocks. Although blockchains can store any data, they are generally used to store information about digital asset transactions, hence they are often described as a ledger.

The ledger is broadcast in a peer-to-peer fashion between participants on the blockchain network. Preset network and consensus rules determine what is acceptable as a transaction and a block, and participants to a blockchain network each validate transactions and blocks according to these rules. This results in each participant holding identical copies of the ledger.

The most well-known blockchain is the Bitcoin blockchain. Bitcoin functions as censorship-resistant digital cash, and is a new payment rail, though its usefulness for payments is tempered by its price volatility. Bitcoin facilitates a more decentralized approach for network-wide agreement on digital asset ownership and payment, with no single institution responsible for settling transactions or maintaining the ledger. This contrasts with traditional payment systems, which involve a series of book-entry adjustments by

specific known and trusted third parties. Blockchains come in many varieties and different architectures and are designed to solve very different problems. Many blockchains use a coin or token to incentivize people to write blocks and maintain the network, and have designs intended to facilitate transfer of that token. For example, the Ethereum blockchain launched in 2015 in an attempt to create an unstoppable global computer, and has a native token called ether. Ether is used to pay participants running nodes on the Ethereum network, referred to as the 'gas fee'.

Traditional permission-less blockchain platforms—in which all data is shared with all parties—have issues around privacy, scalability and interoperability that render them largely unsuited for global businesses. Corda launched as an open source platform in 2016 with a different aim—to make regulated business across many industries more efficient by providing relevant parties to a transaction current and consistent data. Corda doesn't bundle unrelated transactions together into blocks, nor does it broadcast all data to all participants, unlike the public blockchains Bitcoin and Ethereum.



What is an enterprise blockchain?

Enterprise blockchains provide an industry-level system of recordkeeping, allowing multiple parties, none of whom fully trust each other, to come into and remain in consensus as to the nature and evolution of a set of shared facts. This approach facilitates cross-firm and cross-entity information sharing without a central operator or costly retroactive bilateral reconciliation.

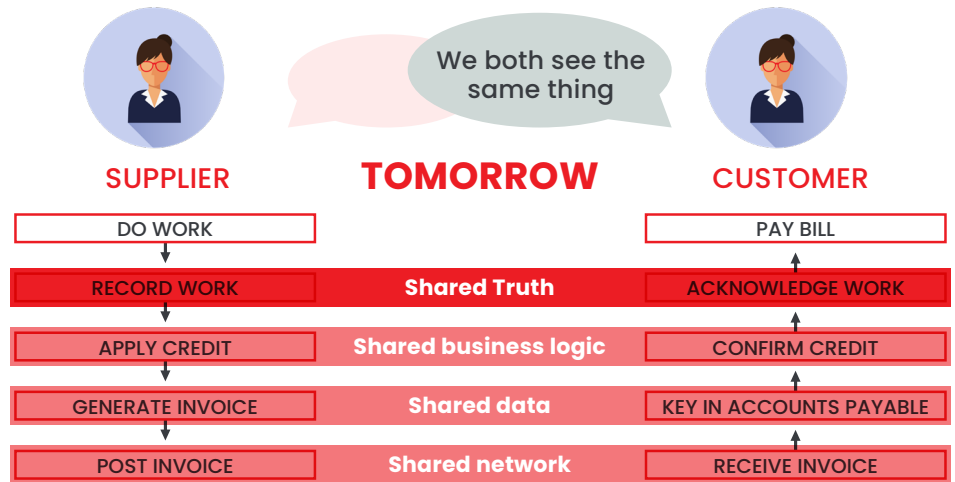

The requirements of businesses that transact are different from the requirements of individuals who want to use censorship resistant digital cash. Because enterprise blockchains solve different problems than public blockchains, they have different designs.

ENTERPRISE BLOCKCHAINS CONTAIN SEVERAL KEY DIFFERENTIATING TRAITS:

- Higher identity standards
- Higher data privacy standards
- Functional requirements of business, such as higher transaction volumes and definitive settlement
- Improved technical support

Regulated enterprises must know who they are transacting with – this requires a robust identity infrastructure in an enterprise blockchain.

Counterparties in business also often require legal agreements to accompany many transactions, and require interactions to occur wholly within the parameters of regulatory requirements.

Regulated businesses also must meet certain compliance standards, such as KYC and AML.

Both specific regulations and general business logic regarding cross-firm information sharing require full data privacy. For example, HIPPA requires that customer healthcare data is private, companies along a pharmaceutical supply chain don't want information

public, and capital markets counterparties don't want their competitors to know their trading history.

Many wholesale payment and capital market use cases require higher transaction throughput, definitive settlement, and advanced multilateral netting capability. The public Bitcoin network can currently process up to 3.5 transactions per second, while the public Ethereum network can process up to 20. Corda Enterprise can process 600+ for 2-party transactions per second (tps) and around 2,000 tps on a single node. Networks using Corda have proven to process 6,300 trades per second.

Settlement is not definitive for many cryptocurrencies and cryptocurrency architectures do not easily facilitate netting. Wholesale payments and capital markets settlements involve significantly larger, definitive, and advanced multilateral settlement capability.

Large organizations also have exacting requirements when it comes to the quality of service or the network infrastructure in which they operate. For example, they require a vendor who supports and facilitates integration with industry-standard enterprise databases such as Microsoft SQL Server and SQL Azure SQL, Oracle and PostgreSQL.

Public blockchains, and the ecosystems around them, do not offer such services.



Who is R3?

R3 is a leading enterprise software firm that builds and maintains Corda, a next-gen blockchain platform developed for every business in every industry. R3's vision is the future of frictionless commerce—where business partners operate in perfect synchrony, and duplicated, inconsistent records are a thing of the past.

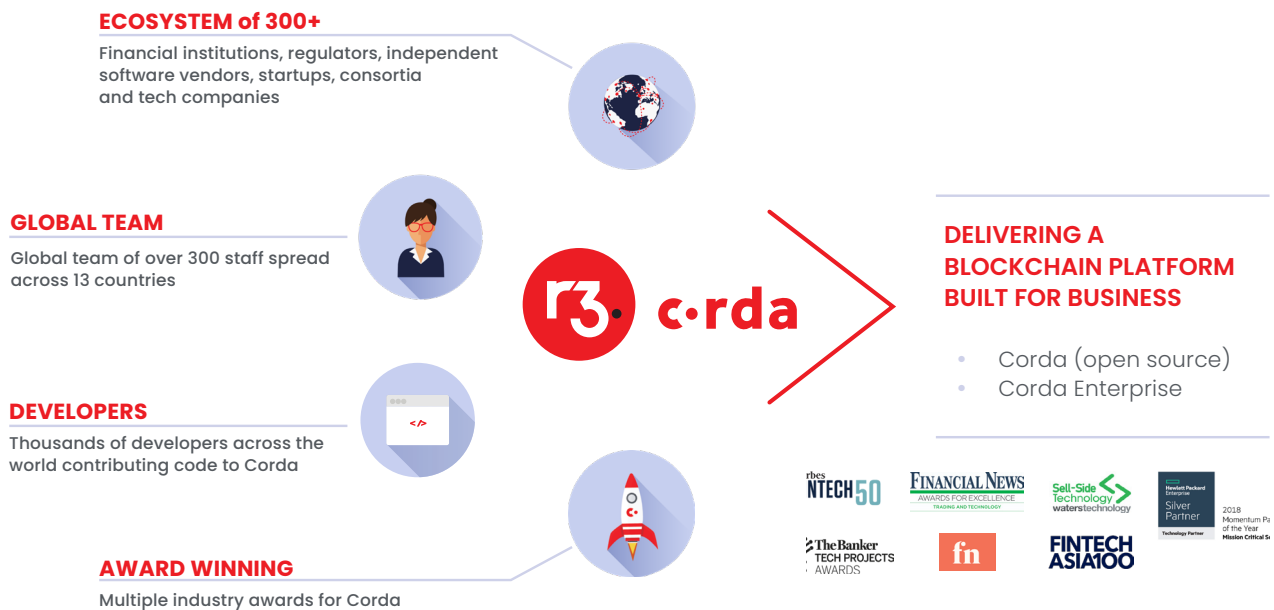

R3 was founded in 2015 in collaboration with some of the world's largest financial institutions. The firm's goal was to match blockchain technology to the needs of specific financial use cases. R3 and its broader ecosystem quickly realized that no public blockchains on the market served the needs of regulated financial institutions, and that initiatives to retroactively meet these requirements through forks or architectural adaptations would not work within a production environment.

This led R3 in 2016 to build Corda, the only open source blockchain platform built specifically for business. The architecture team leveraged the thorough rigorous requirements gathering process within financial services to build a blockchain platform applicable for transactions across any industry and business use cases. Corda enables businesses to transact directly and in strict privacy, reducing transaction and record-keeping costs and streamlining business operations. In 2018, R3 introduced Corda Enterprise—a commercial

version of Corda specifically optimized to meet the demands of modern-day enterprises.

R3 works with an ecosystem of more than 300 participants across multiple industries from both the private and public sectors. R3's global team of over 300 professionals in 13 countries is supported by over 2,000 technology, financial, and legal experts drawn from its global member base.

The R3 team is dedicated to both maintaining Corda by constantly upgrading the platform and providing support to firms building applications on Corda, known as CorDapps, that solve the needs of their clients.



What is Corda?

Corda is an open source blockchain platform that is built to record and manage contracts between mutually distrusting parties. Corda was originally built by R3 in collaboration with the world's largest financial institutions. It was designed to meet the rigorous requirements imposed by financial service regulators, conform to industry standards, and deliver on the promise of blockchain technology making it applicable to any business in any industry.

Corda distinguishes itself from other blockchain platforms through a number of deliberate design decisions. These decisions were made to ensure that the platform could be used to solve real world problems found in any industry.

CORDA HAS THE FOLLOWING CHARACTERISTICS:

- Supports transactions between strictly regulated entities
- Allows counterparties to know each other's identity
- Protects privacy by not globally broadcasting transaction data
- Enables the creation of legally enforceable transactions
- Scales to support a global system of transactions

Corda addresses many of the challenges of building an enterprise-ready blockchain network with its unique point-to-point architecture. This separation allows Corda to achieve the openness of public networks while retaining the security and privacy characteristics of a private network.

Corda removes costly friction in business transactions by enabling businesses to transact directly. Using smart contract and blockchain technology, Corda allows existing business networks to reduce transaction and record-keeping costs and to streamline business operations.

Currently, there are two versions that make up the Corda platform: Corda Enterprise and Corda open-source.

Corda Enterprise is the commercial version of Corda. It is optimized to meet the demands of modern day businesses.

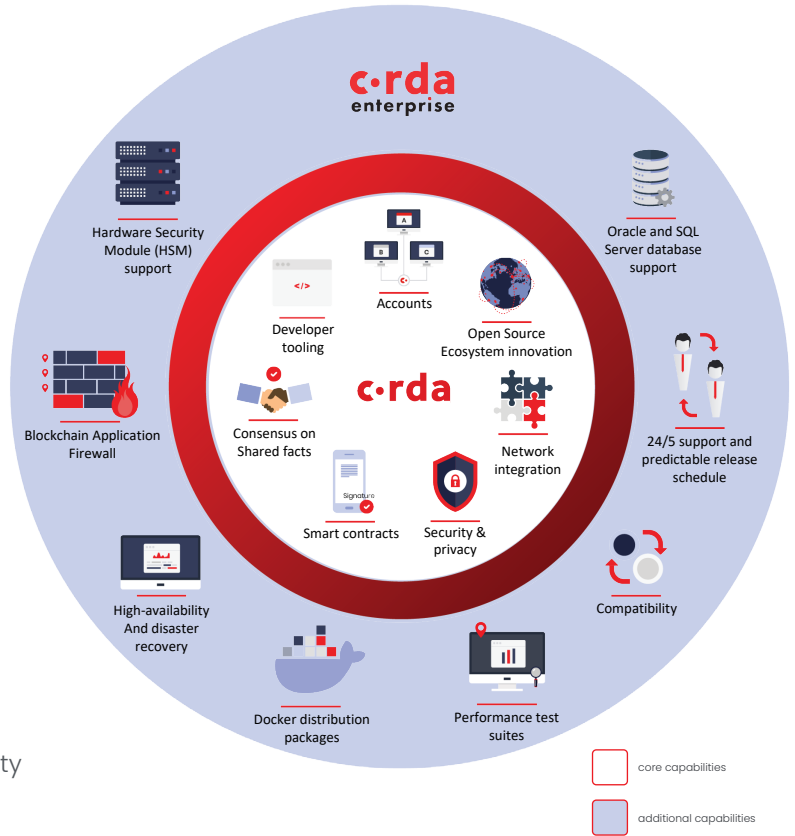

Corda Enterprise is fully interoperable and compatible with Corda open source. It adds mission critical features including, but not limited to, resilience, enhanced security and high availability. It also includes the world's only Blockchain Application Firewall which enables Corda Enterprise to be deployed inside corporate data centers while retaining the ability to communicate securely with other nodes anywhere else in the world.

Corda Enterprise is designed to meet the industry standard needs of the institutions that require commercial production capabilities.

Corda open source is an open application framework that is available to global developers and designed for early adoption, integration and proof of concept development. It is suitable for companies with a relatively simple IT structure. However, many institutions, especially large and complex ones, have more stringent requirements regarding production capabilities. While Corda remains open, Corda Enterprise harnesses the most appropriate elements from the core Corda offering and fine-tunes them for the enterprise market.



How involved are regulators?

Since inception, R3 has made regulatory engagement a key priority for the company. We have done so for a very simple reason: we are looking to deploy Corda in the most heavily regulated industries in the world, and without a comprehensive public/private collaborative working model, the development and deployment of blockchain could be stopped in its tracks. Excellent technology and deep financial experience are not enough to make Corda a success. Public sector actors need to understand what we are building, why we are building it, and how it can improve the functioning of the markets, market participants and the regulators themselves. We clearly see the potential benefits of blockchain and we take it upon ourselves to help regulators see them as well.

R3 has expanded its deep engagement around the world by meeting with more than 150 government agencies at all levels. We have invited public sector actors from around the world to join the R3 ecosystem and currently have over 30 regulatory participants. These broad and deep relationships with regulators have allowed R3 to incorporate key regulatory requirements into the design of Corda. We have hosted two day workshops for regulators, provided deepdives into Corda and our projects, included regulators in projects, participated in over a dozen conferences put on by regulators, responded to 20+ requests for comment from regulators, and trained regulators on Corda.

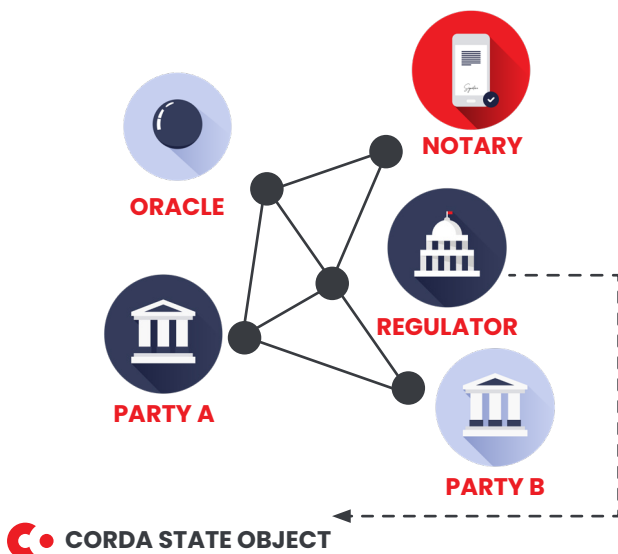

R3 HAS BUILT OUT A PORTFOLIO OF PROJECTS, MANY OF WHICH DIRECTLY INCLUDE REGULATORS AND CENTRAL BANKS AS PARTICIPANTS:

- **Maison:** Regulatory reporting using blockchain technology. With an initial focus on mortgage regulatory reporting, R3 collaborated with the UK's Financial Conduct Authority (FCA) and member banks to develop a near real-time regulatory reporting prototype.
- **Digital Street:** Her Majesty's Land Registry (UK) – Understanding how the innovative use of blockchain, distributed ledgers and smart contracts, could revolutionize the land registration and property buy-sell process.
- **Inthanon:** Collaborative project between the Bank of Thailand and the country's commercial banks to explore the benefits of blockchain for Thailand's financial infrastructure.
- **Lionrock:** Digital currency project undertaken in partnership with the Hong Kong Monetary Authority (HKMA) and the 3 note issuing banks in Hong Kong to develop a Digital Hong Kong Dollar prototype on Corda for interbank payments/securities settlement with provision to wholesale customer.
- **Corda KYC:** 39 firms, along with Banco de la República (Central Bank of Colombia), Federal Reserve of Boston, Superintendencia Financiera de Colombia, and Superintendencia de Banca Seguros y AFP de Peru, partnered to complete over 300 transactions on a Corda KYC platform.

The same design features that make Corda the blockchain built for business also make it built for the public sector. Regulators are more actively exploring possibilities offered by, and opportunities to deploy, blockchain technology. As such, we are now beginning to focus on how to get Corda in front of those in the public sector for consideration as a tool they could use. We are doing that through direct engagement as well as through our partner network. We are already in the process of building custom solutions for the public sector, but anticipate an increase in that activity in the near future.



Data privacy

Unlike public blockchains, Corda is engineered to prioritize the privacy of individual firms' data. Corda already includes many privacy preserving features, and is consistently researching future privacy technologies.

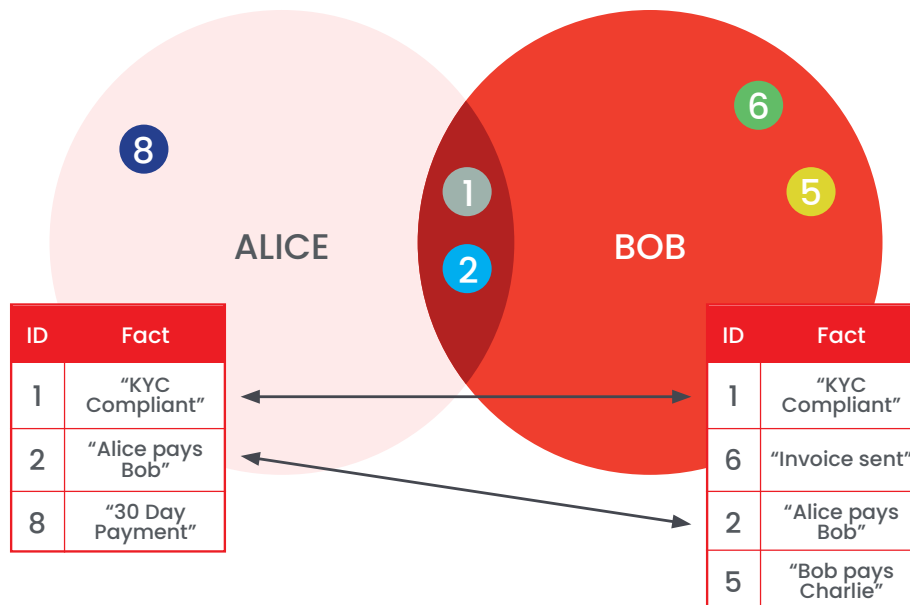

Data within a Corda network travels directly from one party to another. Only parties involved in a transaction are involved in building, validating, and storing it. This contrasts with other blockchain platforms that gossip data widely by default, and then require data privacy layers to obfuscate private data.

In addition, parties have flexibility over what data they share with counterparties. For example, individual subcomponents of a transaction can be generated for counterparties who need to grant approval but should not be able to see all the details. These are called transaction "tear offs".

ADDITIONAL APPROACHES ENHANCING PRIVACY:

- Hardware privacy and multi-party computing
- Mixed-version networks
- Zero-knowledge proofs

Corda has partnered with Intel to deliver end-to-end encryption of transaction history with chips that use Software Guard Extension (SGX) technology. SGX allows all transaction history to be fully encrypted, unreadable even to the parties of the transaction. This ensures that the history of ownership of assets remain private.

As for all blockchains, some nodes may be able to decipher identity of counterparties over time through IP addresses or examining certificates being sent to notaries. Corda could solve this by using a mix network, a cryptographic solution that repeatedly encrypts data in an onion-like fashion, where the nodes in each layer contains the address of the one above it.

Once the technology is mature enough, Corda intends on migrating to zero-knowledge proofs (ZKP). ZKPs allow one party to prove to another party that a statement is true without revealing any information apart from the fact that the statement is true. The technology is extremely novel, and Corda developers have been deeply researching future implementation.



What is consensus?

Consensus is the process of reaching agreement on a set of shared facts.

Blockchains can achieve consensus in many different ways. For example, Bitcoin uses an algorithm called “Proof of Work” to ensure coins granted to one user can’t also be re-used by the issuer. PoW is a cryptographic race between miners (nodes) in order to come to an agreement about which transactions to add to the network. Alternatively, some blockchains achieve this through a mechanism called “Proof of Stake”. Ultimately, each blockchain platform will use the mechanism that most suits their use-cases.

CORDA SUPPORTS TWO SETS OF CONSENSUS:

- Verification
- Uniqueness

All relevant parties need to sign off on the transaction, which is referred to as verification. Since transaction data is only shared with relevant parties, Corda is more private because each actor in the system can only view a subset of network data.

Corda assures that assets allocated in one transaction cannot be re-used for other purposes, which satisfies uniqueness and solves the double spend problem. On Corda Network, double spend is solved by a group of notaries, referred to as the “notary pool”, who assure transaction uniqueness, provide a definitive ordering of transactions and ensure transaction finality. Corda supports multiple pools so each pool can be optimized to cater to differing business processes.

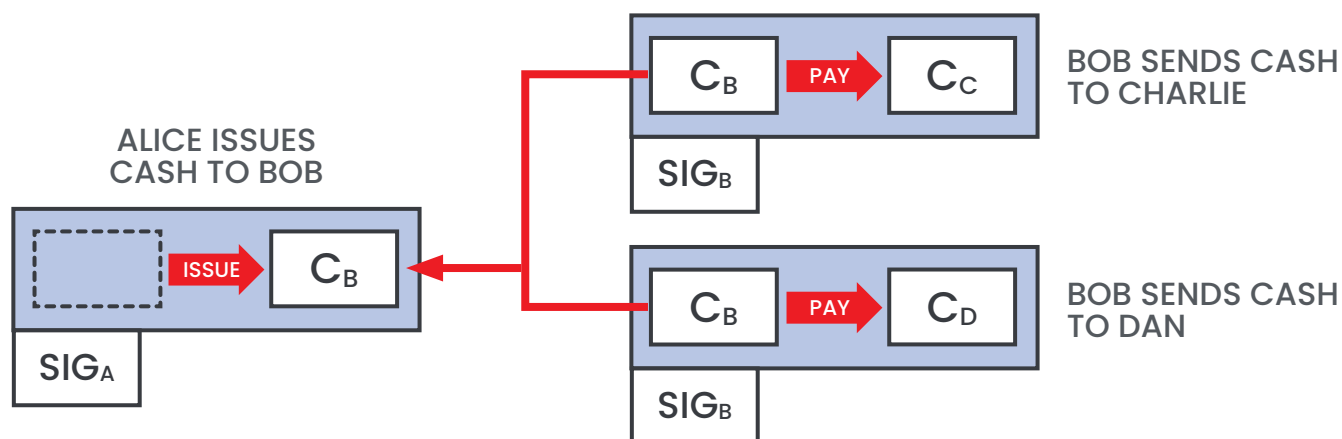

Image shows a violation of double spend

The way parties achieve consensus should be able to change because users of enterprise blockchains operate under a diverse set of trust assumptions. Corda allows for “pluggable” consensus, whereas some platforms are locked to one consensus mechanism for the entire network. For example, parties can choose to use an algorithm called RAFT, which promises high speeds but assumes high levels of trust between parties. Conversely, the BFT algorithm runs at a lower speed but assumes lower levels of trust between parties.



What does decentralization mean?

Decentralization is a process of delegating the functions of one entity to many entities. The most significant difference between centralized and decentralized system is that a centralized system is often controlled, governed, and operated by a single entity. Blockchain technology can decentralize these – enabling entities to coordinate and agree upon information between each other, bilaterally or multilaterally without concentration of processes or data through a single intermediary.

Through a pre-agreed upon consensus algorithm, entities in a blockchain network can maintain collective records without trusting a third party. There also is not a need to retroactively reconcile information between disparate databases when a shared ledger ensuring a correct, current, consistent source of truth exists at all times.

The figure demonstrates the core differences between centralized and decentralized approaches in the context of a decentralized KYC utility. For a decentralized corporate KYC utility, a direct customer-to-bank relationship would remain, without a central operator maintaining the utility and controlling information flows. Third parties, such as attesters of certain identity characteristics, could sign off on relevant facts, but would not have a holistic view of a corporate customer's identity profile.

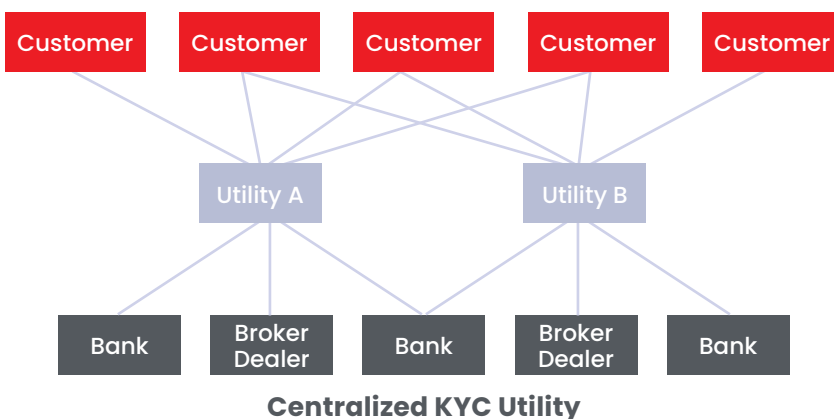
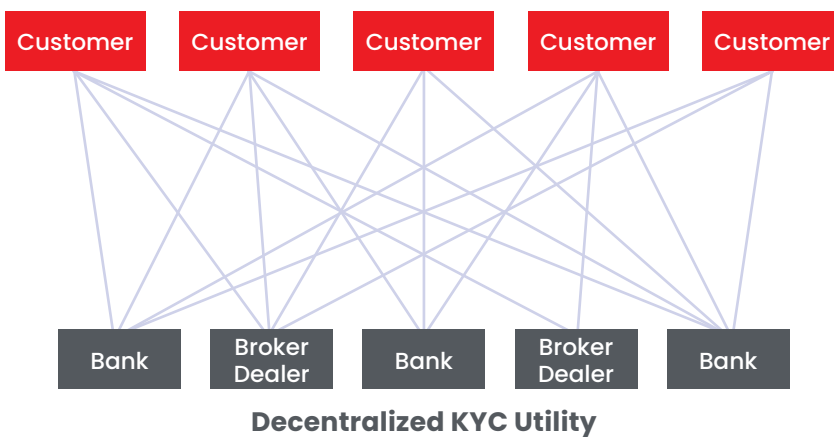

Much of the promise of blockchain technology involves decentralizing who operates and who governs a certain platform. However, no network using blockchain technology is entirely decentralized in all respects, and different blockchain networks have varying degrees of centralization and decentralization. For example, Bitcoin and Ethereum are examples of cryptocurrencies which are designed to be decentralized across the different spheres, but with a concentration of mining power and less governance structure making unintended centralization highly possible.

Many enterprise use cases can benefit from more decentralization. A shift towards more decentralization can reduce the pains of new intermediaries, such as risk concentrations and a regulatory need to ensure these institutions do not evolve into rent-seekers or stifle innovation once established. In the context of corporate KYC, there may be advantages for decentralization across resiliency (no central point of failure), data security and privacy (avoidance of data "honeypots"), and process flexibility (customer-to-bank, instead of linear process dependencies on an intermediary).



What is interoperability?

Interoperability is the ability of different systems to work with each other. In computer systems, it involves the exchange and use of information. Interoperability in the enterprise context can happen at four levels:

- Enterprise IT integration
- Interoperability of business networks in one framework
- Payments and settlement network integration
- Cross chain smart contracts & digital assets

Historically, short-term and localized incentives for IT managers meant that IT departments across several industries often chose the fastest and cheapest ways to support a new product at the expense of holistic considerations for costs and complexity. As new products have been added they often do not interact smoothly with existing IT infrastructure. Corda was built in a way to allow flexibility for integration into these backend systems, and R3 works with large Enterprise Resource Planning (ERP) providers that integrate their systems onto Corda business networks.

In the past, interoperability constraints between different products for financial institutions have limited how efficiently assets can be exchanged. Corda is built to allow CorDapps to seamlessly interoperate with each

other via Corda Network. By enabling interoperability within the platform, Corda delivers the vision of global interoperability initiated by public blockchains, but with the requirements of business. This stands in stark contrast to other enterprise blockchain platforms which must form “channels” or data siloes to achieve privacy. The architectural complexity of retroactively adding core privacy features, makes having multiple interoperating applications even within the same platform becomes very difficult for some platforms. Additionally, open source payment integrations, such as Corda Settler, will be required by these CorDapps to facilitate a variety of obligations.

However, an enterprise blockchain ecosystem with many different platforms would require architecturally intensive adaptations to allow cross-platform transactions and to align static data. Siloed communities without consistent standards would likely introduce many of the interoperability problems that blockchain technology promises to resolve.

As envisioned by R3 CTO Richard Brown, “The win comes when we break down silos; when we enable data and assets to move without friction; when we avoid duplication; when we eliminate reconciliations and unnecessary integrations.”

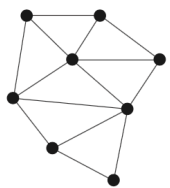

BITCOIN/ETHEREUM

- **RIGHT VISION:** Global interoperable network
- **WRONG DESIGN FOR ENTERPRISE:** Privacy, scalability, programming model wrong for enterprise

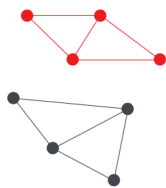

FABRIC/QUORUM

- **WRONG VISION:** Isolated silos with trapped assets
- **WRONG DESIGN FOR ENTERPRISE:** Privacy, scalability, programming model wrong for enterprise



c·rda

- **RIGHT VISION:** Global interoperable network
- **RIGHT DESIGN FOR ENTERPRISE:** Privacy, scalability, programming model designed for enterprise



Who is using Corda? What are some of the applications?

R3 leads the largest blockchain application and project ecosystem in the world, comprised of hundreds of firms building applications on Corda, known as CorDapps, as well as institutions collectively exploring blockchain/DLT and embracing this technology to solve real-world problems.

Independent software vendors (ISVs), startups and consortia across trade finance, insurance, GovTech, collateral management, and syndicated lending are among these early adopters recognizing that they could leverage Corda to unlock new value and transform business problems that have plagued their customers for decades.

powered by
corda

RECENT APPLICATIONS IN DEVELOPMENT AND DEPLOYMENT INCLUDE:

- **Global Trade and Supply Chain**
 - **Contour**: An open trade finance platform reducing letter of credit processing times by 90%
 - **Marco Polo**: Open account trade and supply chain finance application from TradeIX
 - **Monetago**: A fraud mitigation network and commercial paper issuance application, in production in India and Latin America
 - **Ripe.io**: Trust and provenance in the end-to-end food supply chain
 - **Digital Ventures Blockchain for Procure to Pay**: The live blockchain solution for procure-to-pay, with 800+ corporates live, reducing processing times by 50%
- **Capital Markets**
 - **SIX Digital Exchange (SDX)**: Regulated digital exchange being built on Corda to trade digital securities
 - **Tradewind**: Digitize and trade precious metals
 - **GuildOne**: Energy royalty smart contract, tokenization, execution and payment
 - **Finastra Lendercomm**: Enables lenders to see accurate information on-demand for syndicated loan portfolios
 - **HQLA**: Live regulated market with Deutsche Börse, for improved collateral fluidity without requiring securities to move through CSDs. Regulator "DCR tracking view", which reduces risk of fire sales and buys
- **Identity**
 - **Capgemini**: Decentralized KYC and identity data sharing for corporates and banks
 - **Gemalto**: Securing a trusted user's identity through paired public and private keys
- **Cash, Digital Assets, Payments + Settlement**
 - **Central Bank Digital Currency**: Multiple central banks exploring
 - **SWIFT GPI Link**: The first integration of SWIFT GPI with Corda Settler to enable blockchain initiated payments to be tracked and settled on SWIFT
 - **Mastercard**: Blockchain powered cross border payments solution
- **Insurance**
 - **B3i**: Application allowing a cedent to request a quote directly or with a broker
 - **The Institutes RiskStream Collaborative**: Consortium of insurers advancing applications such as proof of insurance, subrogation, data sharing
 - **ChainThat**: Brokers and reinsurers negotiate and manage terms for new risk contracts. Includes accounting, settlement and claims agreement
 - **InsurWave**: Marine hull insurance solution live with 20+ corporates, having processed 50,000+ Txns and 100 million+ in premiums



How does Corda compare to Fabric and Quorum?

Business considerations

	Corda	Fabric	Quorum
Company	R3	IBM	JP Morgan
Open-source	✓	✓	✓
Designed from start with enterprise user input	✓	✗	✗

Platform Considerations

	Corda	Fabric	Quorum
Privacy	Transaction data is only shared with those who need to know. As a result, privacy is not threatened by the network scaling.	Channels architecture allows for private transactions between counterparties. However, there is a constant tradeoff between throughput and level of privacy.	Private deployment (Tessera) is viable. However, private transactions do not support enterprise requirements such as high availability or ledger sync.
Scalability	Scalable as each node does not handle all transactions	Scalability limited by channels architecture. Channels increase exponentially with more participants. Private Data Collection provides a potential workaround, but limits performance.	Need to run more and more databases as networks grow. Impact of public broadcast remains. ZKPs still slow to process and scale.
Settlement Finality	Completed transactions cannot be reversed.	Completed transactions cannot be reversed.	Small possibility completed transactions can be reversed.
Identity	Unique and legally valid real-world identities.	Certificate-based identity with no assurances that identity is related to real-world entity.	No notion of real-world identities.

Enterprise Grade

	Corda	Fabric	Quorum
Data and Hardware Security	Used by the world's most regulated institutions with HSM support, unique blockchain application firewall and Intel SGX development.	Lack of native HSM support. No firewall for on-premises deployments.	Virtual HSM less robust than true HSM. No firewall for on-premises deployments.
Integration	Standard integration with most popular database technologies (Azure SQL, SQL Server, Oracle and PostgreSQL).	Only supports CouchDB and LevelDB, two niche databases with availability concerns.	Platform is run in Solidity, which makes it more difficult to integrate with databases.
Legally binding agreements	Real-world legal prose can be linked to Corda assets.	Network is not designed for any notion of data privacy or sovereignty.	Transactions that have a possibility of being reverse, creating legal ambiguity.



What is Corda Settler?

Corda Settler is an open source CorDapp that allows Corda users to settle payment obligations using any payment rail, supporting cryptocurrencies or other crypto assets, and any traditional rail providing that it can report final settlement to a beneficiary. Corda Settler will initiate a payment and then verify that the beneficiary's account was credited with the expected payment, before automatically updating the Corda ledger. As development continues, we expect Corda Settler to be integrated with all common payment systems, both on- and off-blockchain platforms.

How it Works

When a payment obligation arises on Corda during the course of business, one party has the option to request settlement using an available payment rail, such as XRP, or SWIFT gpi. If needed, an Exchange Rate Oracle provides an FX rate that the parties can agree to use, in order to settle in a different currency. The payee updates the obligation with the payment instructions e.g. beneficiary account number.

The paying party is then notified that settlement has been requested, and that they must instruct a payment to the required account before the specified deadline. The payer uses the Settler to pay using the agreed rail and provides the Settlement Oracle with a transaction reference.

Once the Settlement Oracle confirms that the payment has arrived at the beneficiary's account, it updates the obligation on Corda to "settled".

Corda Settler

Beneficiary Company A
Payer Company B
Face Value 260 EUR
Due By 2018-12-04
Settlement Method [address: ra6mzL1xy9aN5..., oracle: Settlement Oracle]
Status Unsettled
Payments

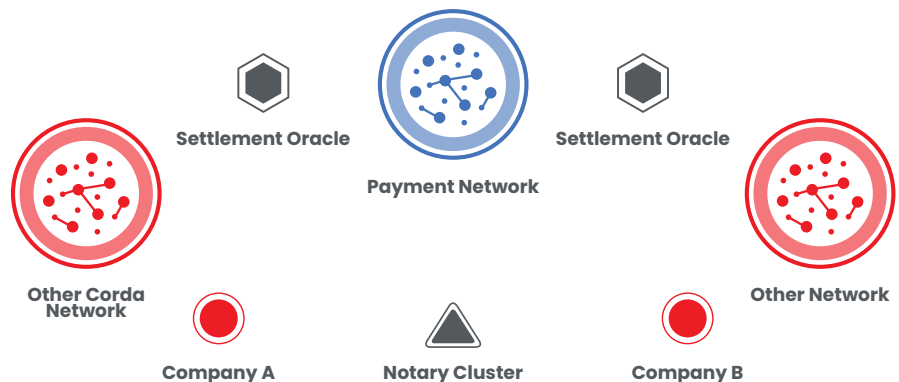

INTEGRATING CORDA SETTLER INTO THE WORKFLOW OF ANY APPLICATION MAKES SETTLEMENT EASY.

- Settle transactions on any payment rail:** Corda Settler is an open source CorDapp that can and will be integrated to all of the most-used payment systems, both on and off-blockchain platforms.
- Integrate with Ease:** With only two integration points required, Corda Settler is easy to integrate with existing payment applications and easy to work with.
- Move value onto Corda with confidence:** Go live with the applications on the blockchain platform built for business, knowing that the tools are in place to settle transactions on any other system, avoiding trapped liquidity and pre-funded accounts.
- Coordination between Corda and other systems:** CorDapp users need to make updates to assets and obligations on Corda based on activity on other platforms. Corda Settler provides a design pattern for developers to do this with ease.

Learn more at www.r3.com/recently-released/settler/



Continue the conversation

 r3.com | corda.net

 [@inside_r3](https://twitter.com/inside_r3) | [@cordablockchain](https://twitter.com/cordablockchain)

 r3.com/blog | corda.net/blog

About this publication

This publication is intended for informational and educational purposes only and does not replace independent professional judgment or advice. No information contained in this publication is to be construed as legal advice. R3 does not assume any responsibility for the content, accuracy or completeness of the information presented or for any loss resulting from any action taken or reliance made on any information included in this publication.

About R3

R3 is an enterprise blockchain software firm working with a broad ecosystem of more than 300 participants across multiple industries from both the private and public sectors to develop on Corda, its open-source blockchain platform, and Corda Enterprise, a commercial version of Corda for enterprise usage.

The Corda platform is already being used in industries from financial services to healthcare, shipping, insurance and more. It records, manages and executes institutions' financial agreements in perfect synchrony with their peers, creating a world of frictionless commerce. Learn more at r3.com and corda.net.